

For translation, large print, audio or Braille, please phone the
Repairs and Customer Contact Centre on 0800 035 1991

Somali

Hadii aad rabtid in lagu turjumo, ama qoraal waaweyn aad u baahantahay, ama hadal
aad dhageysato ama aad u bahan tahay qoraalka indhoolaha bil asxaanag la' Soo xariir
qolooying sameynta oo kala soo xariir numberka 0800 035 1991

Bengali

অনুবাদ, ছাপার অক্ষর, অডিও অথবা ব্রেইল আকারে পাওয়ার জন্যে
অনুগ্রহ করে রিপেয়ার্স টিমকে 0800 035 1991 নম্বর ফোন যোগাযোগ করুন

RESIDENTS REPAIR HANDBOOK



REPAIR GUIDES

5th edition 2009 ISBN: 0 86297 344 9

All text and drawings are subject to copyright.
All rights reserved. No unauthorised reproduction permitted.

Published by Housing Software www.m3h.co.uk

Thanks to the NHMF for drawings, advice and testing the product.



Poplar Housing and Regeneration Community Association
167a East India Dock Road, London E14 0EA

Useful numbers

During normal office hours

To report a repair call the Repairs & Customer Contact Centre Team on:
Freephone **0800 035 1991**

or

main switchboard **020 7510 0500**

(follow instructions to be connected to correct department)

Other numbers

Gas leaks:
0800 111 999 (National Grid/Transco)

Loss of electricity supply:
0800 028 0247

Bulk rubbish removal:
020 7364 5004 (Streetline)

Loss of water supply:
0845 920 0800 (Thames Water)

Independent Housing Ombudsman:
020 7836 3630

Social Services:
020 7364 2034 / 3838

Out of hours emergencies

For out of hours emergencies call:
Freephone **0800 035 1991**

Contact by internet - anytime of day or night

Any repairs (except out of hours emergencies) can be reported directly to the Repairs & Customer Contact Centre (R&CCC) Team 24 hours a day via the Poplar HARCA website:
www.poplarharca.co.uk

Anti-social behaviour hotline:
0800 917 5918 (Tower Hamlets)

Pest control:
020 7364 5007 (Environmental Health Customer Contact Centre)

Noise Nuisance:
020 7364 5007 (Environmental Health Customer Contact Centre)

LBTH Main switchboard:
020 7364 5000

How to report repairs

During normal office hours

The easiest way to report a repair is to call freephone number **0800 035 1991**. This will put you straight through to the Repairs and Customer Contact Centre (R&CCC) Team. The R&CCC Team take calls between 9am and 5pm Monday to Friday. They will ask you questions about the problem. They will let you know how quickly the repair will be carried out, if it needs to be inspected first and make an a.m. or p.m. appointment with you. If you report a repair outside the hours of 9am-5pm (Monday-Friday) the R&CCC Team will call you back the next working day.

If you need to report a repair in person you can do so at Poplar HARCA head office Chrisp Street (at the front of Chrisp Street market) or one of our Neighbourhood Centres:

- Head Office, Chrisp Street
- 167a East India Dock Road
- Burdett - off Wallwood St on Burdett Estate
- Teviot - Wyvis Street
- Aberfeldy - Aberfeldy Street
- Bromley-by-Bow - 1 Bruce Road

You must tell us about any repair that needs doing as soon as you can as this will stop things getting worse and possibly affecting a neighbour's home.

Out of hours emergencies

You can report emergency repairs during evenings, over the weekend and on public holidays by ringing the emergency number 0800 035 1991. Suspected gas leaks should be reported immediately to National Grid/Transco on 0800 111 999. Your contact details are vital in emergencies.

Repairs reported out of hours must be genuine emergencies and include:

- flooding and serious plumbing problems such as burst pipes or complete loss of drinking water supply
- **total** loss of electricity to home
- **complete** loss of heating in the wintertime (October to end of April)
- if, through vandalism or break-in, windows need boarding up or front entrance door needs to be made secure
- removal of obscene or offensive (including racist) graffiti
- breakdown of a lift where there is no other working lift available
- major emergencies such as structural damage caused by fire and/or smoke

Contents

Important equipment

Note where important equipment is in your home. Fill this table in for future reference.

IMPORTANT EQUIPMENT	WHERE IS IT?
Mains water stopcock inside your home	
Consumer unit and trip switch	
Gas supply tap	
Central heating boiler	
Cold water storage tank	
Hot water tank	

For advice on looking after your home see Guidance on page 70.

Introduction

Repair priorities	4
Our responsibility	5
Your responsibility	6
EMERGENCIES	7
Alterations and improvements	8
Who will carry out the repair?	9
Appointments	9
Repair priority and responsibility	10



Plumbing

Baths / basins (sinks)	13
WC (toilet)	17
Showers	19
Water	23
Hot water	25



Doors and windows

External / internal door	27
Windows	35



Kitchens

Kitchens	39
Sinks	41



Heating and electrical

Gas / electrical heating	43
Electrical	47



External

Garden	51
Gates	51
Fences	53
Garden walls	55
Garages	55
Paths and steps	57



Roofs and drains

Roofs	59
Chimney	59
Gutters and drains	61



Communal

External / internal	65
---------------------	----



Stairs and walls

External / internal stairs	67
Walls and floors	69

Guidance

Looking after your home	70
Bulk rubbish removal	70
Condensation and mould growth	70
Smoke alarms	71
Leaking, burst or frozen pipes	71
Asbestos	72
Bleeding a radiator	72
Loss of electric light or power	73
Controlling your central heating	74
Clearing a blocked waste pipe	75
Clearing a blocked WC	75

Useful information

Aerials and satellite dishes	76
Rechargeable repairs	76
Crime and vandalism	77
Bogus callers	77
Complaints	77
Adaptions for elderly and disabled residents	78
Performance and Quality Control	78

Index

	80
--	----

Introduction

Poplar HARCA is committed to providing an efficient and high quality repairs service to its residents. This booklet explains about the service: ie how to report a repair, what your responsibilities are and what to do if things go wrong.

We are continually striving to improve the service and we need your feedback in order to do this. Your co-operation in replying to any questionnaires and surveys would be appreciated and will help to ensure that the service continues to improve.

REPAIR PRIORITIES

We categorise all reported repairs as follows.

Emergency repairs

(within 24 hours - Priority 1)

See Emergencies on page 7 for dealing with gas or water leaks, or loss of electrical power.

An emergency is defined as something which could not have been foreseen and which could cause danger to health, residents' safety, or serious damage and destruction to property. Emergency call out contractors will normally make safe to enable full and proper repairs to be undertaken during normal working hours. The types of work they attend include:

- Unsafe power, lighting socket or electrical fitting
- Severe roof leak

- Burst pipes
- Blocked or leaking drains or soil stacks
- Blockage of your only toilet. This may be rechargeable.
- Loss of electrical power or light
- Loss of gas
- Loss of heating in cold weather where there is no other form of heating available
- Loss of hot water supply
- Insecure external window, door or lock (for health and safety reasons)

We recognise that the elderly and vulnerable residents will need special consideration in certain circumstances.

Emergency repairs will be carried out within 24 hours, with a call or contact within 1 hour of the repair being reported.

Urgent repairs

(within 3 days - Priority 2)

These are repairs which are important but not classed as an emergency. The list includes:

- Partial loss of electrical power or light
- Partial loss of water or gas supply
- Tap which cannot be turned
- Loose or detached banister
- Rotten timber floor or stair tread

Urgent repairs will be completed within 3 days.

Priority repairs

(within 7 days - Priority 3)

These are repairs that materially affect the comfort or convenience of the resident. This list includes:

- Toilet blocked (second toilet). This may be rechargeable.
- Blocked sink, bath or basin
- Minor leak from water or heating pipe, tank or cistern
- Leaking roof
- Door entry phone not working
- Faulty extract fan in kitchen or bathroom (where no window)
- Loss or partial loss of space or water heating in warm weather (eg defective radiator)

Priority repairs will be completed within 7 days.

Non priority repairs

(within 28 days - Priority 4)

These are repairs that can wait up to a month to be completed and will not affect a resident's immediate health or personal safety. See pages 10 and 11.

Planned maintenance

Where maintenance can be planned in advance we can arrange for it to be done on a group of homes at the same time, so as to keep costs down. This will include work to your home to ensure that it remains in good order, and provides safe accommodation for you and your family. Examples include external painting,

repairs to doors and windows in preparation for painting, boiler replacements, annual servicing of gas appliances and central heating, and inspection and testing of appliances that we supply.

OUR RESPONSIBILITY

As your landlord, we have a legal duty to carry out certain repairs when these are needed. Therefore as a Poplar HARCA resident you have a right to expect repair work to be done quickly and efficiently when you report a problem in your home.

What we have to do

- Keep the structure and the outside of your home in good condition
- Repair fixtures and fittings provided by us
- Keep in good repair and proper working order all heating and sanitation, and water, gas and electricity supplies.

Insurance

The building you live in is insured against damage. However, this protection **does not** extend to your own possessions and **it is advisable to take out contents insurance to get things replaced if they are destroyed, damaged or stolen.** This includes fire damage.

If you wish, Poplar HARCA can provide you with cover via an insurance company and the premium is paid weekly with your rent. There is a leaflet that explains this scheme in full - contact Poplar HARCA for a copy.

Annual gas servicing

We have a legal obligation to service your gas appliances annually and your co-operation in allowing us access is essential. *This is vital for your own safety as carbon monoxide poisoning can result from poorly maintained appliances.*

If access is denied, due to the potential seriousness of the problem, we are obliged to take legal action and you will be recharged any legal or other costs.

YOUR RESPONSIBILITY

What you have to do

- Keep the inside of your home clean and in reasonable decorative order
- Report promptly any disrepair or defect which is Poplar HARCA's responsibility to repair
- Take responsibility for minor repairs and any repairs due to damage or neglect caused by you or anyone living with you or your visitors
- If you damage something in your home such as breaking a window or putting a nail through a water pipe, you are responsible for the repair. We may be able to fix it for you but we will charge for the work. R&CCC officers can tell you more about the rules

The following list describes the types of works you are responsible for.

I Redecorations to all internal areas (ideally once every five years). This includes removal of mould growth caused by insufficient use of heating and poor ventilation.

2 Damage Any repair or replacement needed because of damage, misuse, vandalism or carelessness by you, anyone living with you or your visitors. This applies even if the repair is one normally carried out by Poplar HARCA.

If the repair would cause a health and safety risk Poplar HARCA will carry out the repair and recharge you.

3 Minor repairs Any small repairs including:

- Repairs to minor cracks and small areas of blown plaster
- Repair or replacement of door bells
- Replacement of toilet seats
- Replacement of basin and sink plugs and chains
- Replacement of letter plates, numerals, door knockers and bolts on front doors
- Minor repairs to garden gates and fencing. Sheds are gifted so tenants responsibility
- Draught exclusion to windows and front and rear entrance doors
- Replacing light bulbs and fluorescent starters

Exceptions may be made for vulnerable and elderly residents, please seek advice from the R&CCC Team.

Right to repair

'Right to Repair' legislation prescribes the time in which some repairs must be carried out and has been included in Poplar HARCA tenancy agreements. It allows you to request an alternative contractor if the first contractor fails to carry out the repair within the set

timescales. If this contractor fails to complete the works you are entitled to claim compensation of up to £50.

However this does not apply if we have been unable to gain access to your home to carry out the repair, or for expensive jobs.

The repairs covered are small and urgent health and safety repairs only, under £250 in value and indicated in column 4 with a 'Yes' on pages 10 and 11.

EMERGENCIES

Fire

- Dial 999. Get everyone out and do not go back for any reason
- Close all doors and windows
- Warn your neighbours if any of them might be in danger

If you smell gas

If you suspect you have a gas leak you must:

- Turn off the gas supply at the control valve (by the meter)
- Put out all naked flames, do not smoke or use matches
- Report it to National Grid/TRANSCO gas emergency line 0800 111 999) and the R&CCC Team
- Do not turn on or off any electrical switches
- Open doors and windows - vacating the property if necessary.

Loss of water

- In the event of temporary loss of water mains or secondary water supply always

leave taps in the off position and make sure all basins, baths and sinks are clear of obstructions. As soon as the water repair has been carried out the service will be put back on immediately. **IT IS ESSENTIAL THAT TAPS ARE LEFT OFF TO PREVENT POSSIBLE FLOODING.** If not you may be recharged for the damage caused

- If electrics are affected, turn off the electricity at the consumer unit. See page 73
- Contact the R&CCC Team.

Burst/leaking pipes

- Turn off the water supply at the stopcock
- Turn on all the taps
- Switch off the central heating and immersion heater
- Switch off the electricity at the mains if the water is coming into contact with electricity
- Telephone the R&CCC Team or Out of Hours emergency service
- Once burst/leak repaired all taps to be turned off as soon as possible

To prevent the problem of burst pipes when going away during a cold spell you should:

- Leave some heating on a low setting if your home is only going to be empty for a day or two
- Drain all the water out of the system if you are away longer than 2 days. Turn off the supply at the stop cock and leave the taps on until the water stops running.

If you are unsure of the location of your stop cock or need further advice contact the R&CCC Team.

Loss of electricity

If you find that your lighting or power sockets are not working it could be that a switch has tripped on your circuit breaker board. 'Circuit breakers' on your fuse-board (located in your meter cupboard, usually in the hall way) automatically switch off when there is a problem with an appliance or fitting connected or plugged in to one of the electrical circuits. See page 73 for more advice.

If problem persists contact the R&CCC Team as soon as possible.

ALTERATIONS AND IMPROVEMENTS

You must obtain written consent from Poplar HARCA before making any improvements, alterations or additions such as new kitchens, windows, porches, satellite dishes etc. Poplar HARCA will not unreasonably withhold its consent providing all other consents (eg planning permission and building regulations approval) have been obtained.

It is advisable to always obtain several quotations and to use trades people who are members of recognised professional organisations such as the Federation of Master Builders or the Chartered Institute of Building to carry out works in your home.

Compensation for home improvements

If you have undertaken improvements within your home and are now moving out you may be entitled to compensation. You should

submit an application 28 days **prior** to ending your tenancy.

In order to receive any compensation you must have received written permission for the improvement and had a quality inspection of the works by Poplar HARCA. Poplar HARCA will also need to see an invoice that shows the cost of your improvement.

The value of any improvement reduces as time passes, so the amount of compensation you may receive depends upon the age and the condition of the improvement when you submit your claim. The law tells us how we calculate your compensation.

Applications for home improvement compensation received after 28 days of moving may not be accepted.

A leaflet is available from Poplar HARCA which explains the procedure in detail.

WHO WILL CARRY OUT THE REPAIR?

Poplar HARCA has its own in-house repairs operatives who carry out small urgent repairs. These include small plumbing, joinery and electrical jobs.

Residents should not approach repairs operatives directly - all repairs should be reported to the R&CCC Team who pass the information to the repairs operatives. Residents are given an appointment to ensure work is done with minimal disturbance.

More complex repair requests, such as drainage and door entry systems are carried out by our specialist contractors. An appointment to carry out the works will be made at the time you report your repair.

Contractor code of conduct

All contractors must abide by the Poplar HARCA customer care code for contractors. A full copy of this can be obtained from the R&CCC Team. The main requirements in this code are for contractors to:

- Refrain from inappropriate behaviour
- Dress in a tidy, clean and presentable manner
- Take the utmost care of residents' furniture and belongings
- Obtain residents' permission to use electricity within their homes
- Carry and show an identification card containing as a minimum a colour photograph, name of the operative, contractor's name and telephone number
- Remove all rubbish daily and not to use residents' rubbish facilities
- Immediately investigate any complaints about a specific job and report the findings to Poplar HARCA

If you do not feel you have received a good service from a contractor please report this to the R&CCC Team who will investigate your complaint.

APPOINTMENTS

Residents will be given either a morning (a.m.) or afternoon (p.m.) time for non emergency repairs.

We will make an appointment with you for a mutually convenient date and time.

If you are subsequently unable to keep this appointment please show consideration to our staff and contractors by notifying the R&CCC Team 48 hours before an appointment, so that it can be cancelled immediately and another appointment can be made. If we are not informed promptly of your need to cancel you may be charged for the inconvenience.

If you are not at home when a contractor calls they will leave a card so that you can contact them yourself to arrange another appointment. If no card is left you will need to contact the R&CCC Team the next working day to make another appointment as these repairs **will not** be done Out of Hours.

Please contact the R&CCC Team promptly as orders are cancelled if we do not hear from you within 14 days. Poplar HARCA reserves the right to charge for abortive calls.

If an appointment is broken by the contractor and they have not informed you and agreed an alternative date and/or time, you are entitled to compensation of £10 for a missed appointment. You must report this within 24 hours to the R&CCC Team for a claim to be considered. The R&CCC Team can give you more details on how to claim.

WORKING OUT YOUR REPAIR PRIORITY AND RESPONSIBILITIES

Examples of repair type and description	Priority	Right to repair?	Who?
PLUMBING AND DRAINAGE			
Repair burst pipe or stack	1	YES	HARCA
Blocked drains (causing backsurge of waste water)	1	YES	HARCA
Blocked toilet (where no other toilet on premises)	1	YES	HARCA unless blocked by misuse
Blocked toilet (second toilet)	3	NO	HARCA unless blocked by misuse
Tap which cannot be turned	2	YES	HARCA
Repair minor plumbing leak (eg dripping tap)	3	NO	HARCA
Blocked sink, bath or basin	2	YES	HARCA unless blocked by misuse
SANITARY FITTINGS			
Bath surface damaged	3	NO	Resident
Broken or missing WC seat	4	NO	Resident
DAMPNESS AND WATER PENETRATION			
Flooding from neighbouring property or roof	1	YES	HARCA
Roof leak (minor)	3	YES	HARCA
Minor leak from water or heating pipe, tank or cistern	3	YES	HARCA unless damage by resident
Rising damp and leaking overflow	4	NO	HARCA
ELECTRICAL WORKS			
Total loss of electrical supply	1	YES	HARCA
Unsafe plug socket or light switch (eg sparking)	1	YES	HARCA
Broken or faulty plug socket	3	YES	HARCA unless damage by resident
Broken or faulty light switch	3	YES	HARCA unless damage by resident
Faulty extractor fan in internal room with no window	3	YES	HARCA
HEATING AND HOT WATER			
Total loss of heating or hot water supply	1	YES	HARCA
Partial loss of heating (eg defective radiator)	3	YES	HARCA
Partial loss of hot water supply	2	YES	HARCA
WINDOWS AND DOORS			
Front entrance door unable to close or lock	1	YES	HARCA
Window unable to close/lock and is security/health & safety risk	1	YES	HARCA
Broken glass in window/door and is possible security/injury risk	1	YES - TNT	Resident *
Repairs to front entrance doors & frame (where there is a security risk)	1	YES	HARCA
Repairs to front entrance doors & frame (no security risk)	4	NO	HARCA unless damage by resident

Examples of repair type and description	Priority	Right to repair?	Who?
WOODWORK			
Loose or detached banister	2	YES	HARCA
Loose stair tread	2	YES	HARCA
Damage to internal door, lock or kitchen worktop	4	NO	Resident
Damage or wear and tear to kitchen cupboards	4	NO	Resident if damage
ROOF			
Water flooding into premises	1	YES	HARCA
Loose and falling gutters, slates or tiles	1	YES	HARCA
Leaking or blocked rainwater gutters/pipes or gully	3	NO	HARCA
INTERNAL WALLS AND DECORATIONS			
Plaster damage or cracks	4	NO	Resident for minor cracks & small areas
Plaster loose and falling off	4	NO	HARCA for large areas
Redecorations	-	NO	Resident
EXTERNAL WALLS			
Structural damage to brick walls	1	NO	HARCA
Minor cracking	4	NO	HARCA
CEILINGS			
Minor cracking on ceiling or on join between ceiling and wall	4	NO	Resident
DRINKING WATER			
Loss of supply	1	YES	HARCA
Concerns over quality/contamination	1	NO	HARCA
COMMUNAL AREAS AND FACILITIES			
Lift not working (where only one lift in building)	1	YES	HARCA
Lift not working (where there is more than one lift in building)	2	YES	HARCA
Door entryphone system not working	3	YES	HARCA
Racist or obscene graffiti and refuse chute blocked	1	NO	HARCA
Total failure of communal lighting	1	YES	HARCA
Graffiti removal (non racist or obscene)	4	NO	HARCA
Faulty garage door lock	4	NO	HARCA
Bulb replacement required for communal staircase lighting	3	YES	HARCA
EXTERNAL BOUNDARIES			
Damage to gate or gate post	4	NO	Resident
Minor repair to gate, latch or fence	4	NO	Resident
Broken or rotting fence panels or posts	4	NO	HARCA
TV AERIALS			
Loss of reception	4	NO	HARCA

* Unless crime/vandalism with CAD number

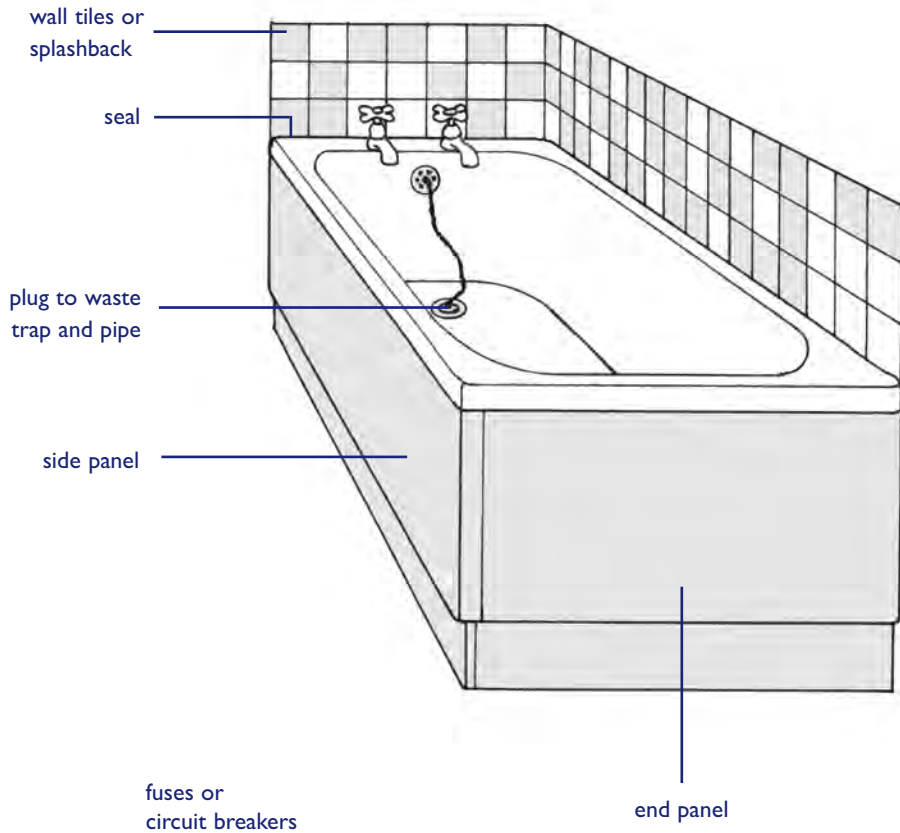

ELECTRICITY CONSUMER UNIT

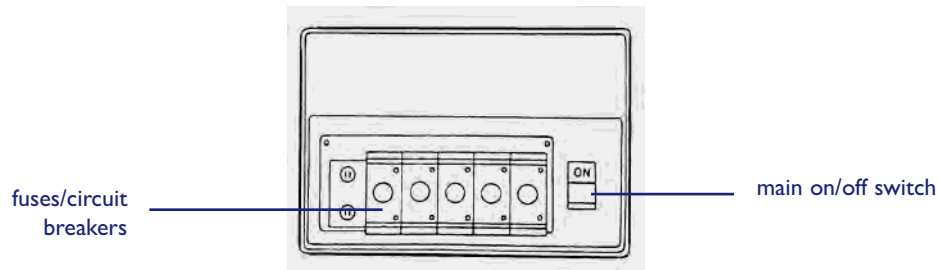

Before you contact us:

- If water is near electrics, do not touch. Turn electricity off at consumer unit main switch.
- Stop leak causing more damage.

- Can you clear blockage yourself? (see Guidance page 75)

Tell us:

Bath/basin water leaking

- Are electrics affected?
- Where is leak? (bath or basin)
- What is affected? (waste pipe/trap, supply pipe or tap. See page 14)
- If pipework is affected, is it hot or cold supply pipe, or waste pipe/trap?

Bath/basin blocked

- What is blocked? (bath or basin)
- What caused the blockage?

Bath or basin damaged/broken

- What is damaged? (bath or basin)
- What is affected part made from? (metal, plastic or china etc)
- If a bath panel is affected, which panel (side or end panel) and what is it made from (hardboard or plastic)?
- Does it need to be replaced or refixed?

Bath panel loose

- Which bath panel is affected? (side or end panel)
- What is it made from? (hardboard or plastic)



BASINS (SINKS)

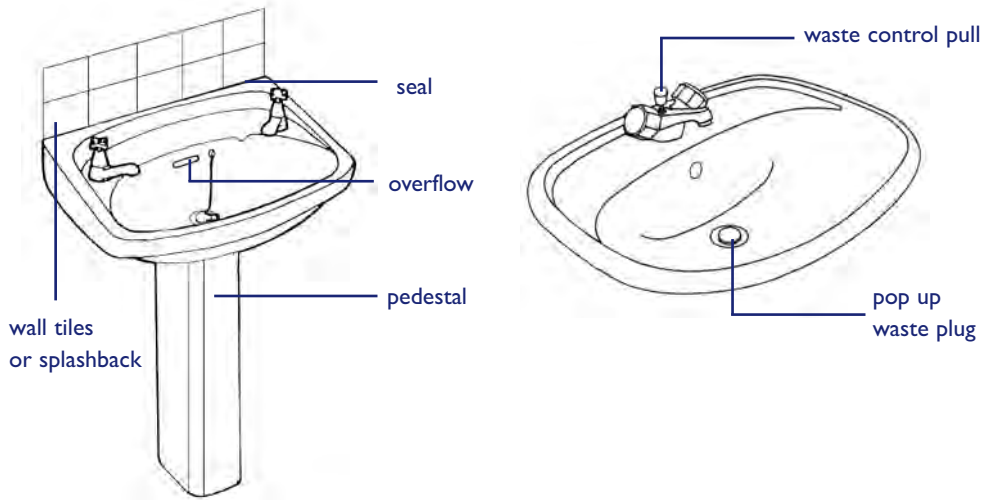

TAPS

Standard pillar tap



Modern pillar tap



High neck pillar tap



Lever tap

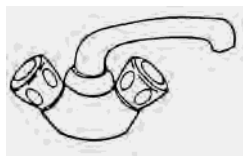

Mixer tap



Supatap



Bib tap

Before you contact us:

TIP - Blocked sink or toilet

The most common cause of blocked kitchen sinks is the emptying of food and fats down the sink. Grease from solid fats builds up slowly in the pipe, eventually causing a total blockage.

Toilets get blocked by toilet blocks falling into them or by nappies or other sanitary items being flushed down them, and baths and basins are frequently blocked by a build up of hair.

To solve the problem:

- Use a sink plunger available from supermarkets and DIY stores
- For kitchen sinks blocked by grease, proprietary liquids can be obtained from supermarkets and DIY stores which can be poured down the sink.
- Flexible drain rods can be bought at DIY stores to release the blockage.
- On most sinks with plastic pipework the u-bend (trap) under the sink can be easily unscrewed to release the blockage - ensure a bucket is placed underneath before unscrewing the pipe. Bottle traps are unscrewed from the bottom. Metal waste pipes may have a cleaning eye at the bottom of the u-bend which can be unscrewed.

To help prevent it happening again:

- Specialist proprietary cleaning liquids can be used once a year as a precautionary measure to keep pipework clear.
- Do not put any items into the toilet other than toilet tissue and human waste.
- Use liquid detergent instead of loose washing powder or tablets in washing machines.
- Use oils for cooking instead of solid fats where possible. Do not tip food or any fats which will solidify (eg meat fat, butter or margarine) down the sink.
- Use a sink guard available at DIY stores to prevent any food entering the sink waste pipe.

Tell us:

Damaged wall tiles

- Where are tiles?
- Are they loose, broken or damaged?
- How many are affected?
- What size and colour are they?
- How did it happen?

Seal gone around bath



Seal gone around basin



Bath tap dripping

- What type of tap is it? (see diagrams page 14)

Basin tap dripping

- What type of tap is it? (see diagrams on page 14)

Basin loose

- Are brackets loose or broken?
- Is basin loose on its brackets?
- Is pedestal broken?

Tap loose

- Bath or basin tap?
- What type of tap? (see diagrams opposite)

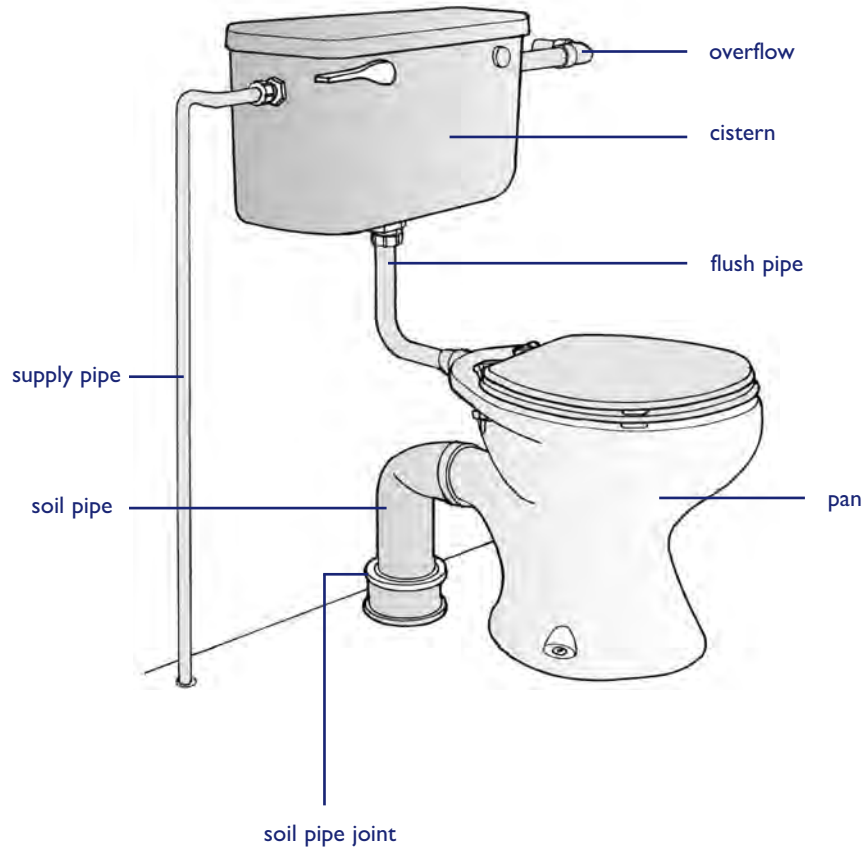

Before you contact us:

- Try to stop leak and any damage it is causing.
- If serious, turn off water at stopcock and gate valves from cold water tank. Open all taps to drain water from system. Turn off heaters affected.

- Has water authority said that water would be going off?
- You can use a bucket of cold water to flush until problem is fixed.

- As a temporary solution, tie float in the up position, thus closing the ball valve.

Tell us:

WC leaking

- Where is leak? (pan, cistern, overflow, supply, flush or waste pipe or pipe joint. See diagram opposite)
- If leak is from cistern, is it high or low level cistern?
- Is affected part loose, cracked or broken?
- Is it your only WC?
- Is it a coloured WC or white?

WC will not flush

- Is the handle or chain moving properly?

Overflow running

- Does the overflow run outside?
- Is the cistern flushing?
- Is the float working?
- Is overflow running continuously?

WC loose

- Is pan or pipe broken?



TIP - Blocked sink or toilet

See page 15

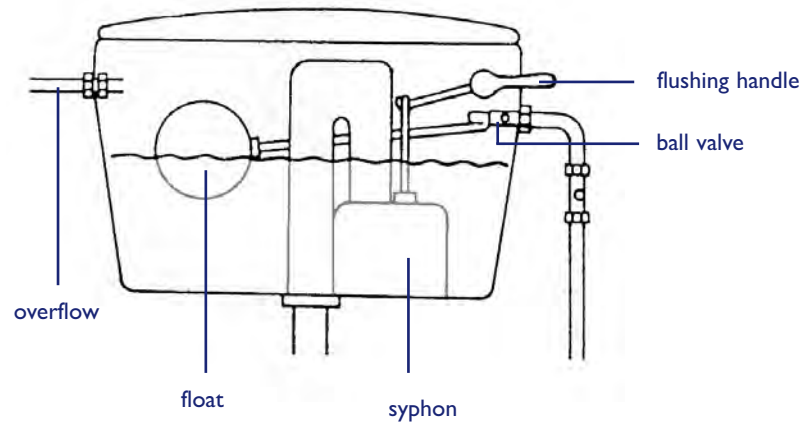

BATH / SHOWER MIXER TAP

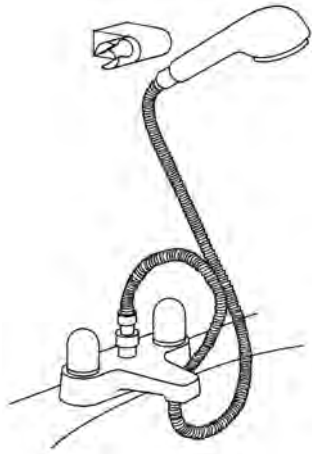

Before you contact us:

- Try unblocking it yourself by removing excess water into a bowl, and using a toilet brush or plunger (without metal disk). (See page 75 for help)

Tell us:

WC blocked

- What caused blockage?

Soil stack blocked

- Do you live in a house or flat?
- If a flat, which floor are you?
- Is your WC causing the blockage?

Seal gone around shower tray

Shower tray broken

- What is it made of? (ceramic or plastic)

Shower not working

- What type of shower is it? (eg electric, over the bath)
- What is happening? (no water, or only hot or cold water)
- Do you have hot water in rest of home?
- Can you see a make or model number on shower?

TIP - Shower and shower attachment

See page 21



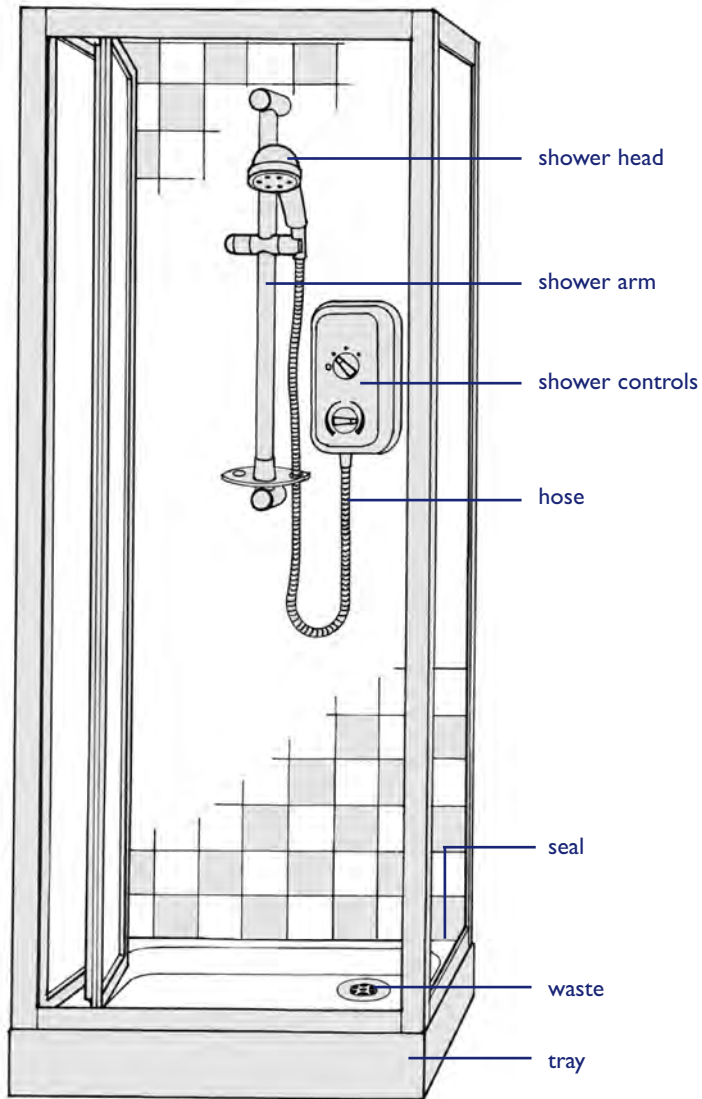

Before you contact us:

- If limescale is the problem, use descaler fluid which can be bought from a DIY shop.
- If you have installed a shower this will be your responsibility to repair or replace

TIP - Shower and shower attachment

If you have a shower installed or a shower hose fitted to your bath you need to ensure that this is flushed through regularly to prevent the growth of Legionella bacteria. This bacteria flourishes when water is left stagnant (as in the case of an unused shower hose).

As a precaution, if not used regularly, a shower should be turned on and run until hot at least once a week. If the shower is left unused for a longer period the shower head should be removed, the hose placed in the bath and hot water run through for 2 minutes. The head should then be cleaned with normal bathroom cleaning agents and replaced.

Tell us:

Shower blocked

- What is causing blockage?

Shower switch broken

Shower hose broken

- This is resident's responsibility

Shower arm broken

- How did it happen?

Damaged wall tiles

- Are tiles loose, broken or damaged?
- How many are affected?
- What size and colour are they?
- How did it happen?

Cubicle door not working

- Is it broken or stuck?

Shower tray leaking

- Has the seal around the tray gone?



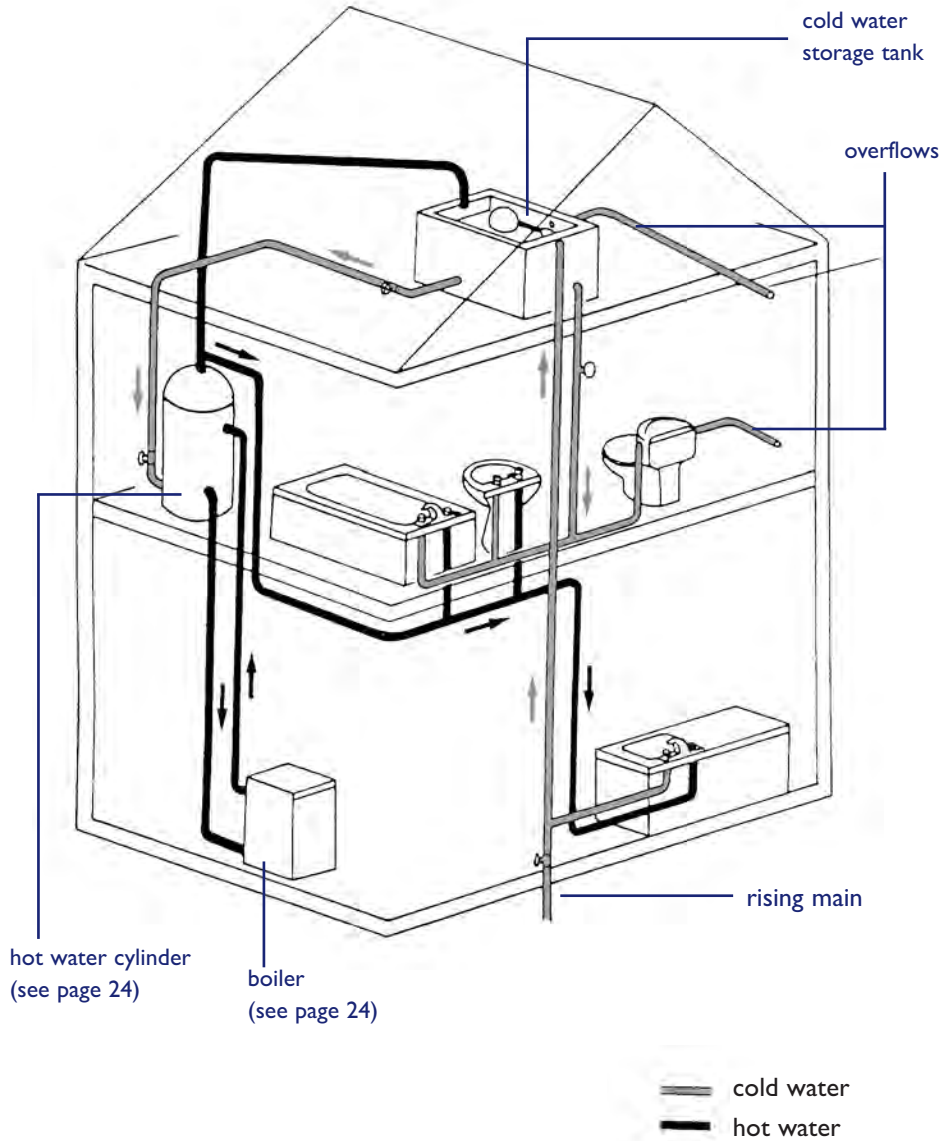

Before you contact us:

- If water is near electrical fittings, turn off electricity at consumer unit main switch. (See page 73)
- Can you stop leak or isolate it? Try to catch water in a bowl or bucket. (See page 71 for help)
- Adjust main stopcock where water comes into home.
- Are neighbours affected?
- Make sure taps are turned off, even though no water is coming through.

Tell us:

Burst pipe

- Are electrics affected by burst?
- Is it inside or outside building?
- Are pipes frozen?

Water leaking

- Is pipe, tank or cylinder leaking?
- Are electrics affected?

Banging pipes

- How often is it happening?

No cold water

- Is there cold water at kitchen sink?
- Are pipes frozen?

Storage tank overflow running

- Is overflow running outside?





GAS BOILER

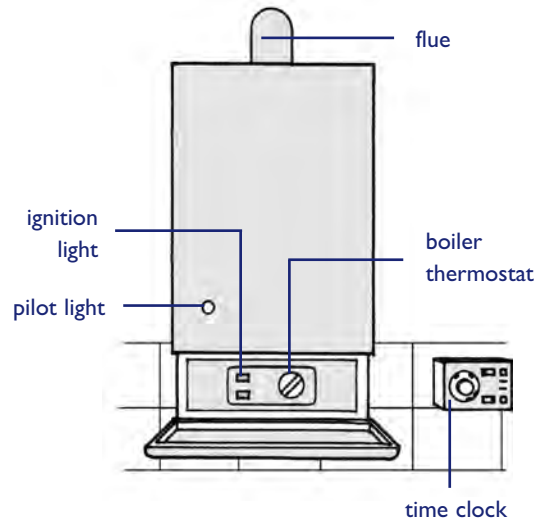

Before you contact us:

- If gas, check time clock controller is set for hot water and timer is set correctly.
- If electric, is there a power cut? Are neighbours affected? If so, contact your electricity company (check your electricity bill for the number).
- If coin or credit meter, has it has run out of credit?

Tell us:

No hot water

- What heats water? (gas, electric, or solid fuel)
- If electric, are other electrical facilities working?
- Are heating controls set correctly?
- Is room heating still working?
- Do you have alternative source of hot water? (immersion heater or gas heater etc)
- Do you have a hot water cylinder?

Water temperature

- Is water too hot or too cold?

- Ensure your cylinder thermostat is adjusted to minimum 60°C

TIP - Hot water temperatures

To prevent bacteria from breeding in hot water cylinders the temperature must be kept at a minimum of 60°C. If the temperature is lower than this, then bacteria such as Legionella, E-coli and Coliforms will breed and may cause serious illness. If you do adjust your thermostat at any time you must ensure that you do not lower the temperature to less than 60°C.

GAS METERS

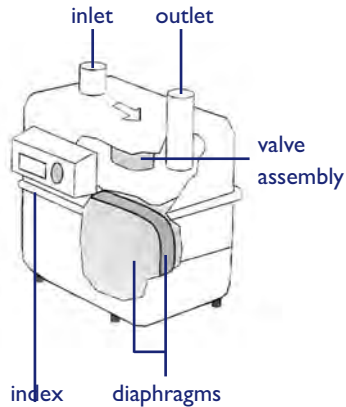

HOT WATER CYLINDER

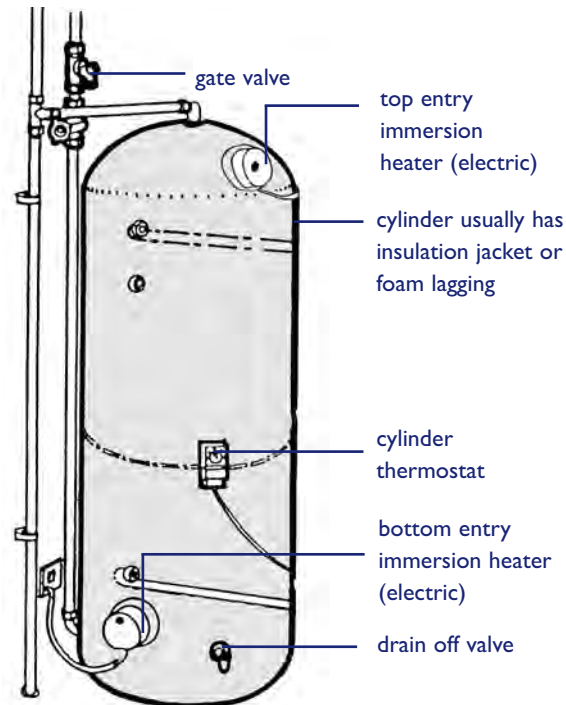

TOKEN METER

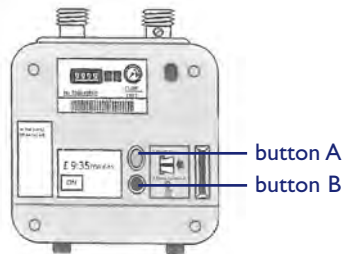

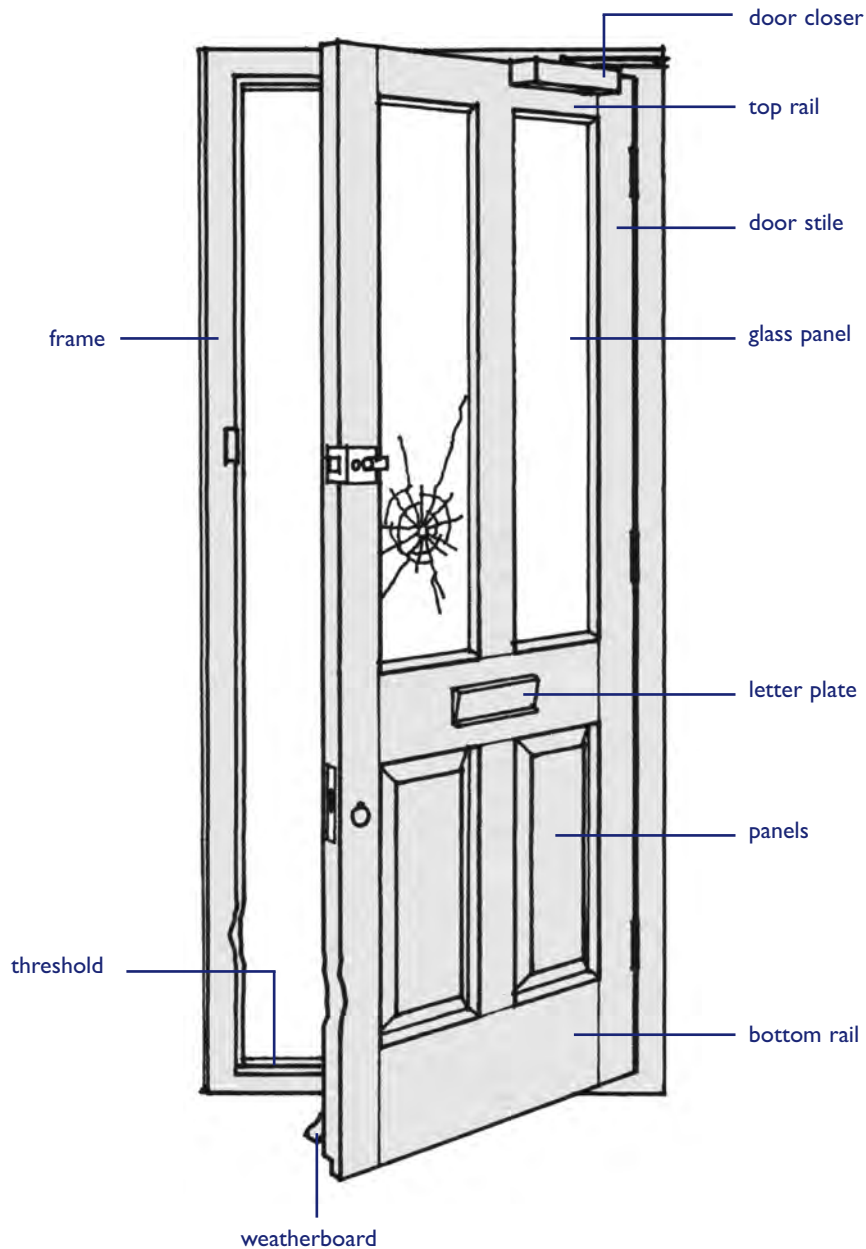

Before you contact us:

Tell us:

Door jammed

- Is it front or rear door?
- What is door made of?
(wood, metal or plastic etc)
- Is door jammed open or closed?
- Can you still get in and out of your home?

Door frame damaged/rotten

- Is door or frame affected?
- Is it front or rear door?
- What is door made of?
(wood, metal or plastic etc)
- What is wrong with it?
(damaged or rotten)
- Is home insecure as a result of this problem?

Threshold rotten/needs repair

- What is it made from?
(wood, metal etc)
- What is wrong with it?
(rotten, broken etc)

TIP - Security grilles and gates to windows and doors

These can cause delays to emergency services in the event of fire. Poplar HARCA and the Fire Service therefore strongly advise against these being fitted.

It is at Poplar HARCA's discretion to give permission for a window grille to a window and only in exceptional cases where a high security risk is demonstrated. If installed with or without Poplar HARCA's consent and need to be removed for access due to an emergency, Poplar HARCA will not be responsible for damage or replacement.

Permission for security gates will not be given where high security (Secured by Design) front doors are installed.



Rim night latch - Yale or similar

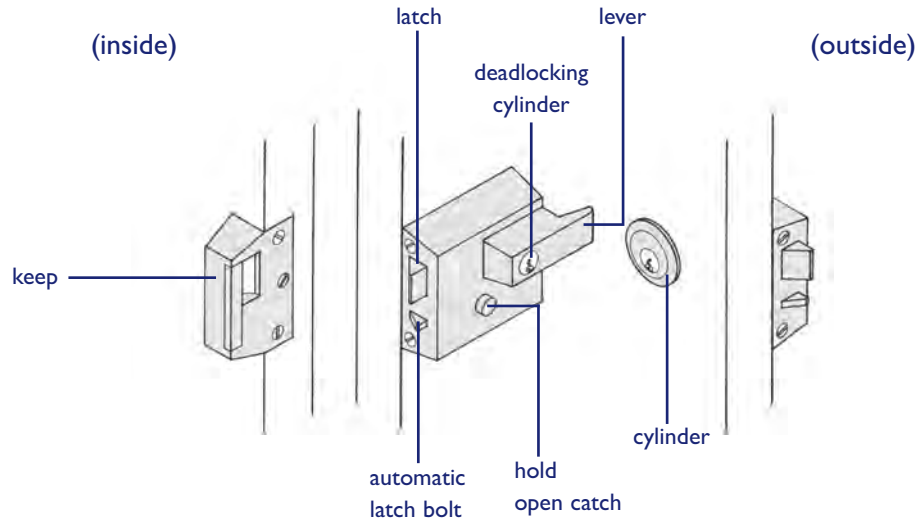

Mortice deadlock

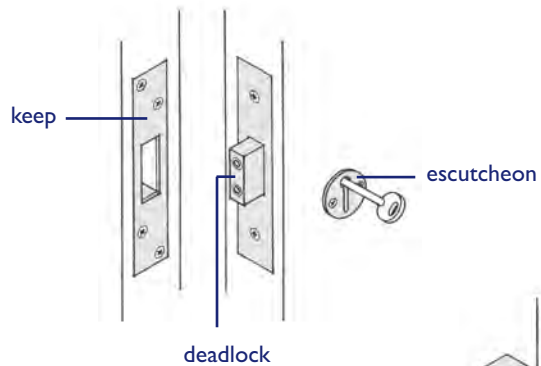

Rim lock

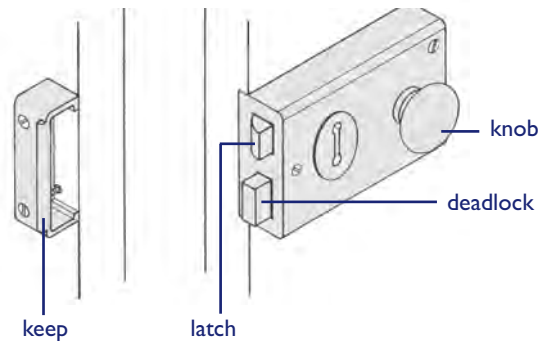

Before you contact us:

Tell us:

Weatherboard rotten/broken

- What type of door is it?
- What is it made from? (wood, metal or plastic)
- What is wrong with it? (rotten, broken etc)

Glass damaged

- What type of door is it?
- If fully glazed, which panel(s) is damaged?
- Is it your own door or a communal one?
- Is it front or rear door?
- Is it single or double glazed?
- What type of glass is it? (clear, wired or obscure)
- Is your home secure?

Draught coming around door

- Where is draught coming from? (between wall and frame, around door or under door)
- Is there any draught proofing around door?

Rain coming in under door

- Does door have a weatherboard? (See diagram on page 26)

•Lost keys or locked out, see page 31



Internal door latch

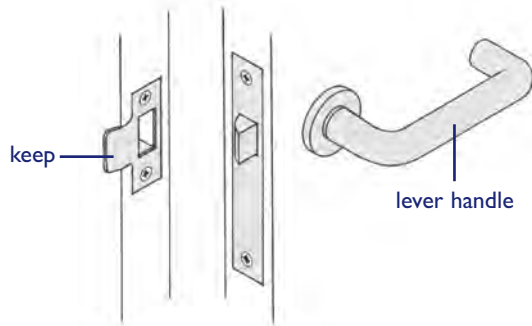

Mortice claw bolt deadlock for sliding doors

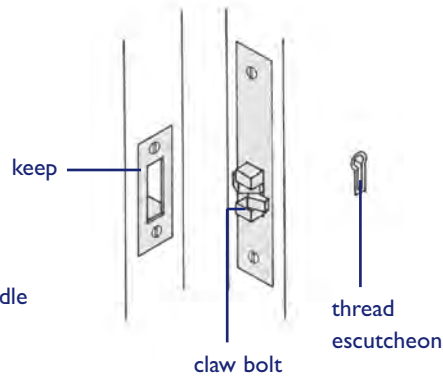

Mortice sash lock

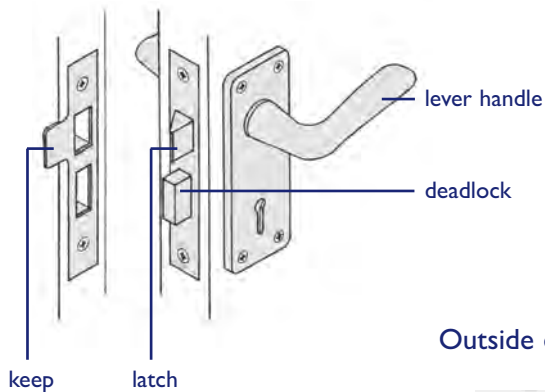

Outside door pull

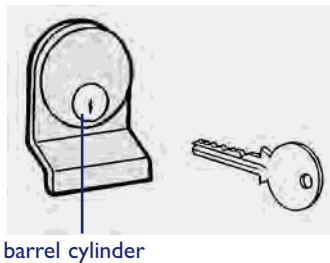

Before you contact us:

- Resident's own locks are your own responsibility.

Tell us:

Door lock not working

- What type of lock is it? (See diagrams opposite, page 28 and page 32)
- What is wrong with lock? (lever handle faulty, spring worn out, striking plate out of place or lock not fitting into keep etc See diagrams opposite, page 28 and page 32)
- Which door is affected?
- What is door made of? (wood, metal or plastic)
- Is your home secure?

Keys lost/locked out

- If you lose your keys or lock yourself out of your home you **will be** recharged for replacement keys or gaining entry to your home. This is a discretionary repair and Poplar HARCA will base its decision to carry out the work on a residents vulnerability status.

- Are you locked out of your home?
- What type of lock is it? (See diagrams opposite, page 28 and page 32)
- Where is door? (front, rear, patio or store)
- You are responsible for your keys and Poplar HARCA will recharge at its discretion if we carry out any lock/key replacement. This includes Out of Hours emergencies.

Door fittings missing/not working

- Resident's own fittings are your own responsibility.

- What fitting is it? (letterplate, handle, chain, door viewer, house numbers etc)
- Is door not closing properly?
- Is your home insecure?



PERKO DOOR CLOSER

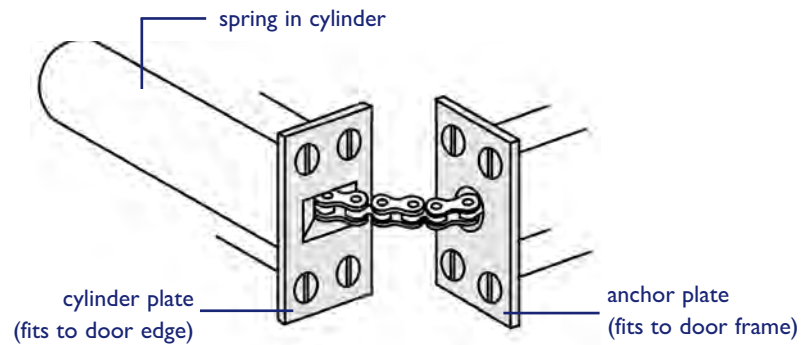

DOOR LATCH

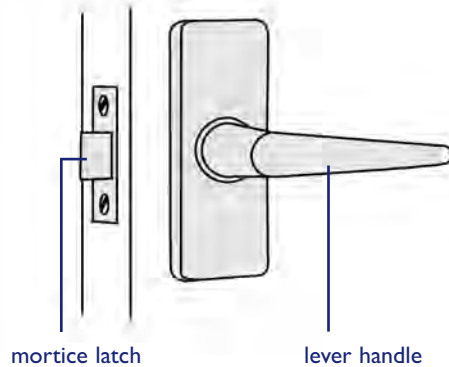

DOORS & WINDOWS

Before you contact us:

Tell us:

Door sticking/jamming

- Where is door?
- What type of door is it?
- What appears to be the problem?

Door damaged

- Where is door?
- What type of door is it?
- What appears to be the problem?
- How did it happen?

Door latch defective

- What type of latch fitting is it?
(See diagrams opposite and page 30)
- Where is door?
- What is wrong with it?
- How did it happen?



Sash window

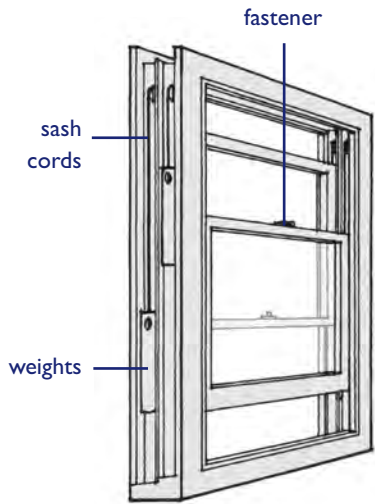

Casement window

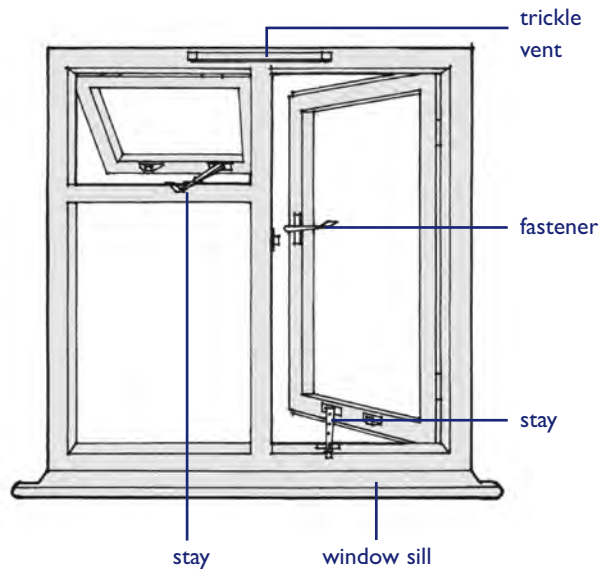

Tilt and turn window

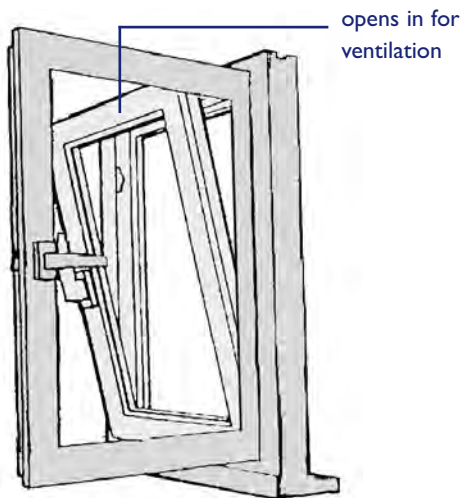

Pivot window

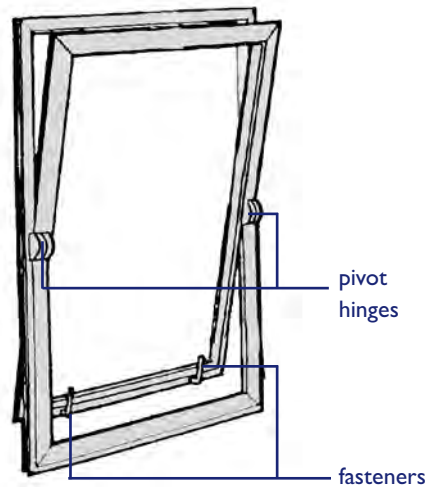

Before you contact us:

- If you can do it safely, remove any loose broken glass which could be dangerous to others, and wrap it in newspaper before binning it.

Tell us:

Glass damaged

- Is it single or double glazed?
- Where is window? (which floor of the building, a communal window or one to your home)
- What type of glass is it? (clear, wired, or obscure)
- What is window frame made of? (wood, metal or plastic)
- Is your home secure?

Window frame jammed/damaged

- What is frame made of? (wood, metal, or plastic)
- What type of window is it? (sash, casement, pivot or tilt and turn window etc. See diagrams opposite)
- What is causing problem? (rotten wood, hinges or sash cord broken etc. See diagrams opposite and page 36)
- Is your home secure?

TIP - Security grilles and gates to windows and doors

See page 27



Fitch sash fastener

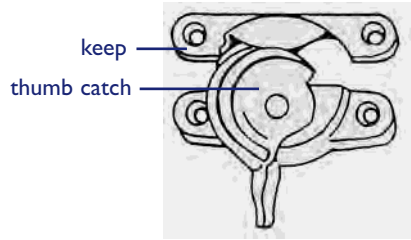

Brighton sash fastener

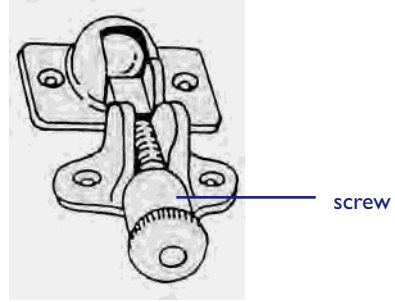

Casement fastener

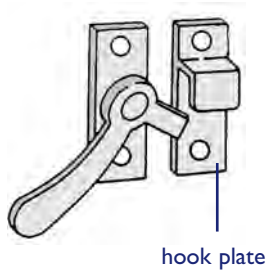

Restrictor stay
Restricts window opening

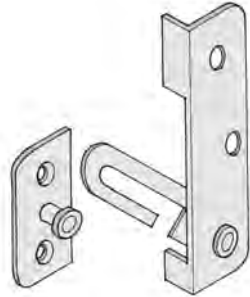

Casement stay

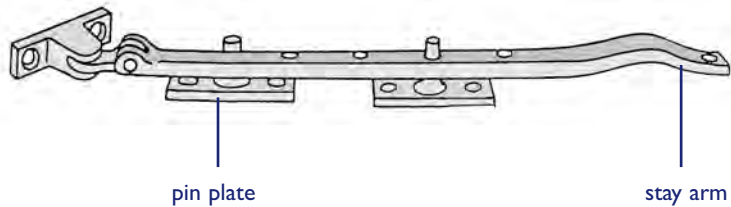

Before you contact us:

Tell us:

Window fittings defective

- What type of window is it?
(sash, pivot or tilt and turn window etc
See diagrams page 34)
- What is frame made of?
(wood, metal or plastic)
- What part is defective?
(stay, catch, fastener, lock or lift etc
See diagrams opposite and page 34)
- Is your home secure?



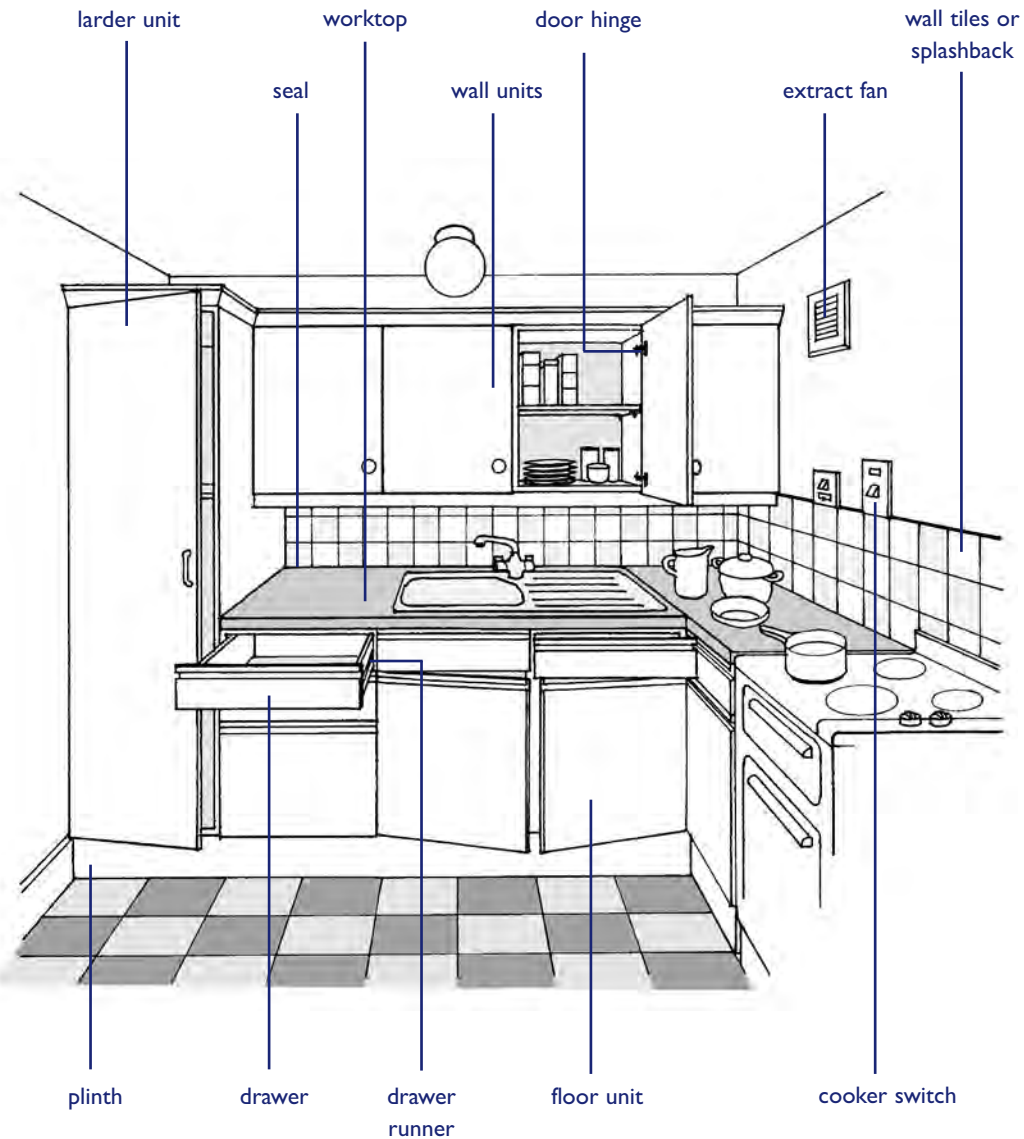

Before you contact us:

Tell us:

Damaged cupboard

- Which unit is affected?
(a corner unit, floor or wall unit, with single or double doors)
- What part is faulty?
(See diagram opposite)
- In what way is it damaged?
- What is it made of?
(wood, plastic or metal etc)
- What colour and size is it?

Doors and shelves

- What part is broken (door, hinge)?
- Is shelf in kitchen unit loose or broken?
- Is shelf in wall or floor unit?

Damaged drawer

- Is the drawer broken or sticking?

Worktop damaged

- Is worktop loose or broken?
- How did damage occur?

Damaged wall tiles

- Where are tiles?
- Are they broken, loose or missing?
- How many are affected?
- What size and colour are they?

Important notice - gas cookers

As from January 2008 all new gas cookers bought for use within a **flat** must have a flame supervision device (FSD). This regulation **does not apply** to cookers which were manufactured before January 2008 or to cookers in houses



WASHING MACHINE

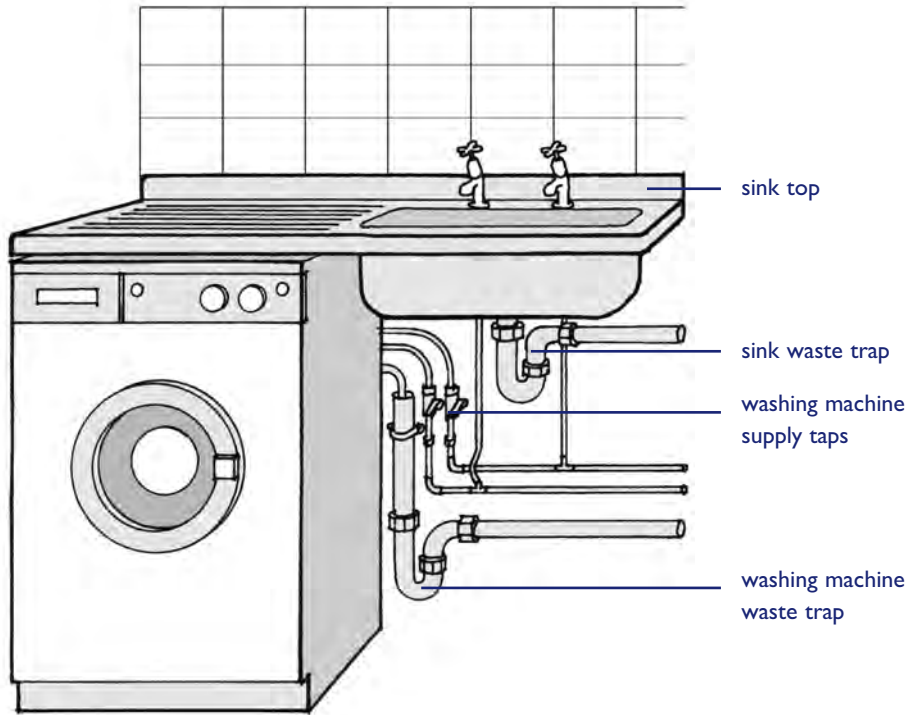

TAPS

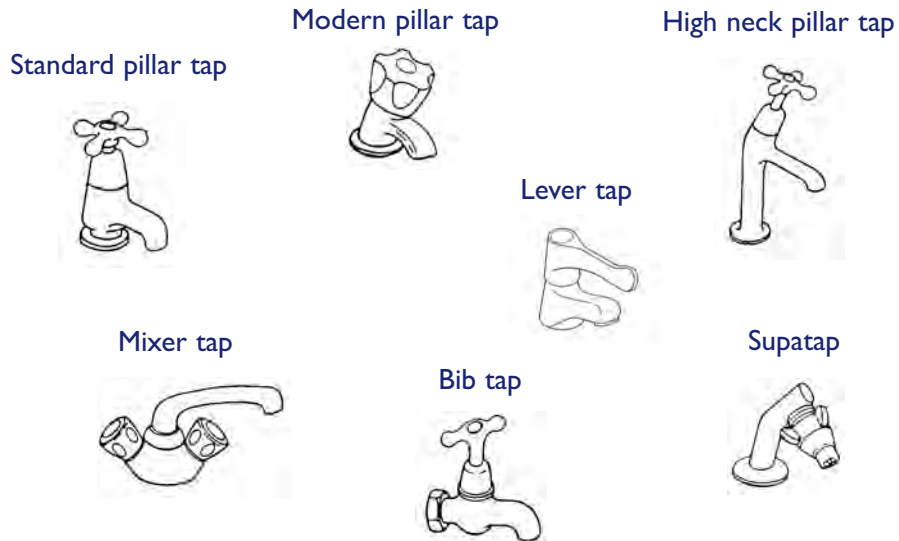

KITCHENS AND SINKS

Before you contact us:

- Try to stop the leak causing more damage.
- Try to clear it yourself using a plunger. (See Guidance page 75)
- Stop others using sink while blocked.

Tell us:

Washing machine blocked

- Do you know what caused the blockage?

Waste trap leaking

- What type of waste trap is it?
- Is it leaking from the joint?

SINKS



Sink unit leaking

- Where is leak coming from? (pipe, tap or waste pipe/trap. See diagram opposite)
- What is it made of (plastic, copper)?

Sink blocked

- Are other outlets affected?
- Is washing machine blocked?
- What caused the blockage?

Seal gone around sink

Sink tap dripping

- What type of tap is it?
(See diagrams opposite)

Sink top

- Is sink top loose or broken?
- Is entire sink unit damaged?

Tap loose

- What type of tap is it? (see diagrams opposite)

GAS BOILER

CENTRAL HEATING PUMP

HEATING AND ELECTRICAL

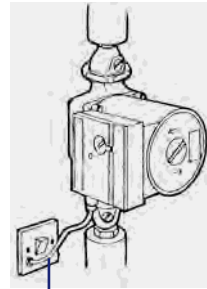
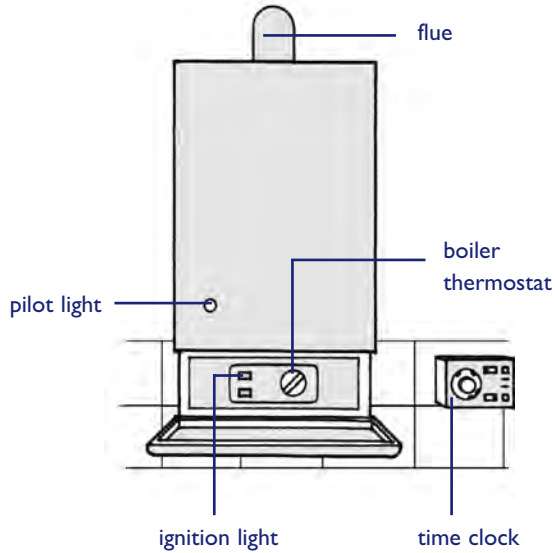

HEATING CONTROLS

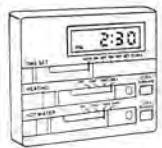

Digital programmer

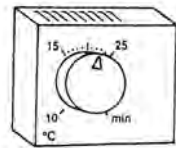

Room thermostat



Clock programmer

Before you contact us:

- If electric, check that power is still on, and that meter is still in credit.
- If gas, check that pilot light is on.
- Check that boiler thermostat is set correctly (See diagram opposite).
- Check that clock or digital timer is set correctly (see page 74 for help).
- Check that room thermostat is set correctly.
- Are other flats affected?
- If you have a warden or caretaker, contact them.

- Check that thermostatic valve is turned up enough (see diagram opposite).
- Try bleeding radiator. (See page 72 for help)

Tell us:

Central heating boiler faulty

- Is it your only source of heat?
- Do you have hot water?
- Can you see manufacturer's name and what model it is?

Communal heating faulty

- Is this your only source of heat?
- Is there any hot water?

Radiator not heating up

- Is thermostatic valve turned up enough?
- How many radiators are affected?
- Is radiator warm at the bottom and cold at the top?
- Have you tried bleeding radiator(s) affected?
- Do you have hot water?



Wall mounted convector heater

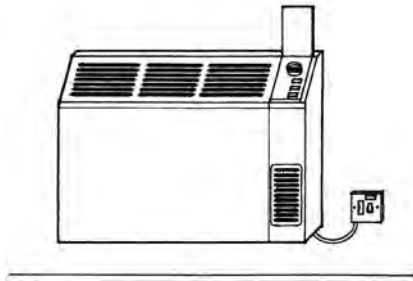

Storage heater with convector

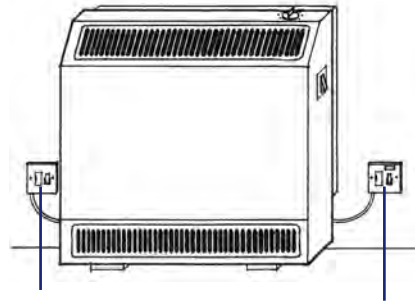

off-peak supply for storage heater

supply for convector

Panel radiator

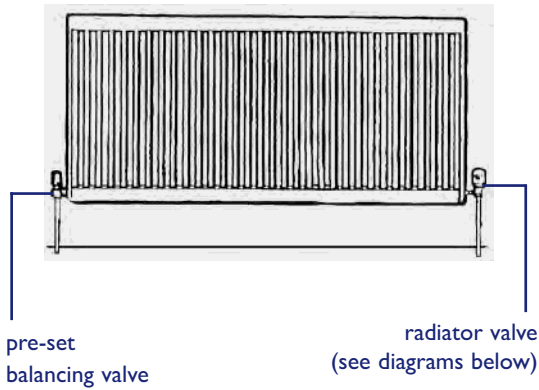

pre-set balancing valve

radiator valve (see diagrams below)

Manual radiator valve

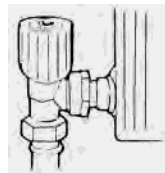

Thermostatic radiator valve

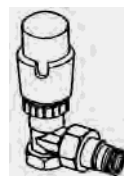

RADIATOR VALVES

Before you contact us:

- Try to stop leak causing damage.
- Turn radiator valve off.
- If gas leak, do not smoke, use matches, or turn electrical switches on or off. Open windows. Follow emergency action outlined on page 7.
- Turn off any appliances that are causing fumes.

- Make sure heater is turned on at socket.
- Check thermostat is set correctly.
- If no power in rest of home, see page 47.

- Check thermostat is set correctly.
- If faulty plug, see page 49.

Tell us:

Radiator leaking

- Where is leak coming from? (Valve, pipe joint, radiator panel. See diagrams opposite)

Fumes in room

- What is causing fumes?
- Has flue been cleaned recently?
- If the heating system is the cause, can you see manufacturer's name and the model?

Storage heater defective

- How many heaters are affected?
- Where are they?
- What appears to be the problem?
- Can you see manufacturer's name and model number?

Radiant/convector heater faulty

- What appears to be the problem?
- Can you see manufacturer's name and model?



ELECTRICITY

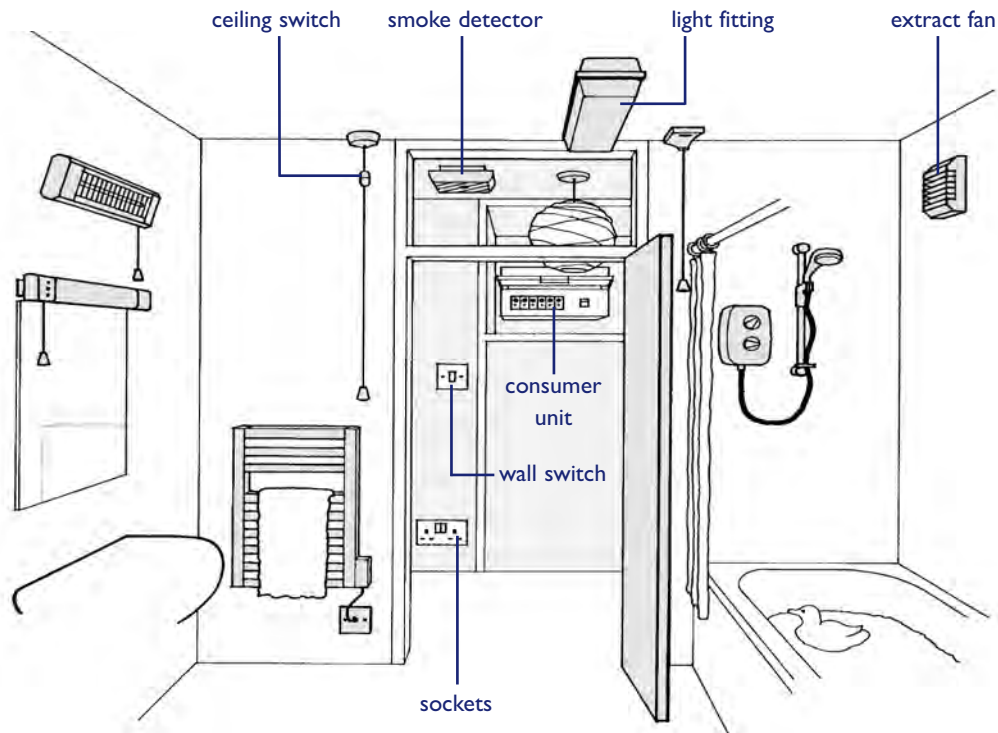

ELECTRICITY METER

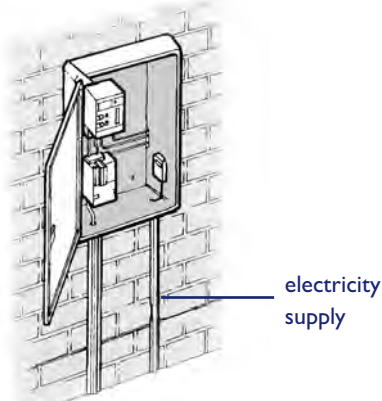

TRIP SWITCH Replaces fuses in modern consumer units



HEATING AND ELECTRICAL

Before you contact us:

- Is fan switched on?
- If you have a coin or credit meter, check that it has credit on it.
- See if trip switch is activated or a fuse has blown on consumer unit. (See page 73 for help)
- Are your neighbours affected? If so, contact your electricity company (check your electricity bill for the number).
- Do not touch fitting.
- Turn electricity off at consumer unit main switch.
- See if trip switch is activated or fuse has blown on consumer unit. (See page 73 for help)
- Has bulb blown?
- Are power sockets working?
- Replacement of fluorescent tube and starter is resident's responsibility.

Tell us:

Extract fan faulty

- Where is fan?
- What type of fan is it?

No power at all

- Is yours the only property affected?
- Has trip switch been activated or a fuse blown on the consumer unit?

Electrical fitting smoking

- What fitting is it? (light, plug etc)
- Where is it located?

Light circuit failed

- Are power sockets working?
- How many lights are affected?
- Is light fitting causing the problem? (the pendant, batten holder, wall or ceiling switch etc. See diagrams opposite and page 48)

Fluorescent tube not working

- What is the problem? (tube flickers, broken etc)



PLUG SOCKETS

Single plug socket

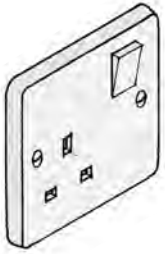

Double switched plug socket

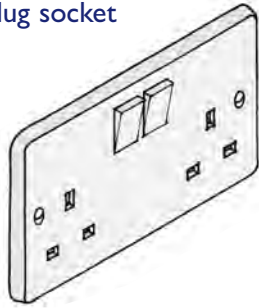

Cooker control plug socket



LIGHTING

Ceiling pull switch



Pendant lamp holder



Batten lamp holders



angled lampholder

SMOKE DETECTOR / SMOKE ALARM

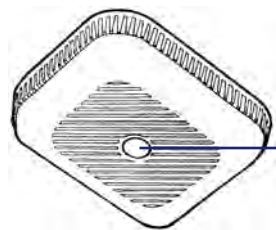

test button

Before you contact us:

- Is it appliance rather than power socket that is faulty?
- Is trip switch activated or a fuse blown in the consumer unit? (See page 73, for help).
- Is there no power at all in your home? If so, see page 47.

- Resident's own appliance is resident's responsibility.
- Is it power socket rather than appliance that is faulty?
- Has fuse blown in the plug? If so, renew it with a suitably rated fuse.
- Is trip switch activated or a fuse blown in the consumer unit?
- Is there no power at all in your home? If so, see page 47.

- If it is battery operated, check batteries and change them.
- Smoke alarm batteries are resident's responsibility.

Tell us:**Plug socket not working**

- Are other power sockets working?
- Is trip switch activated or a fuse blown in consumer unit?

Appliance not working

- Are other power sockets working?
- Is trip switch activated or a fuse blown in consumer unit?

Smoke detector defective

- Is it battery operated?
- Where is the smoke detector?
- What appears to be problem?



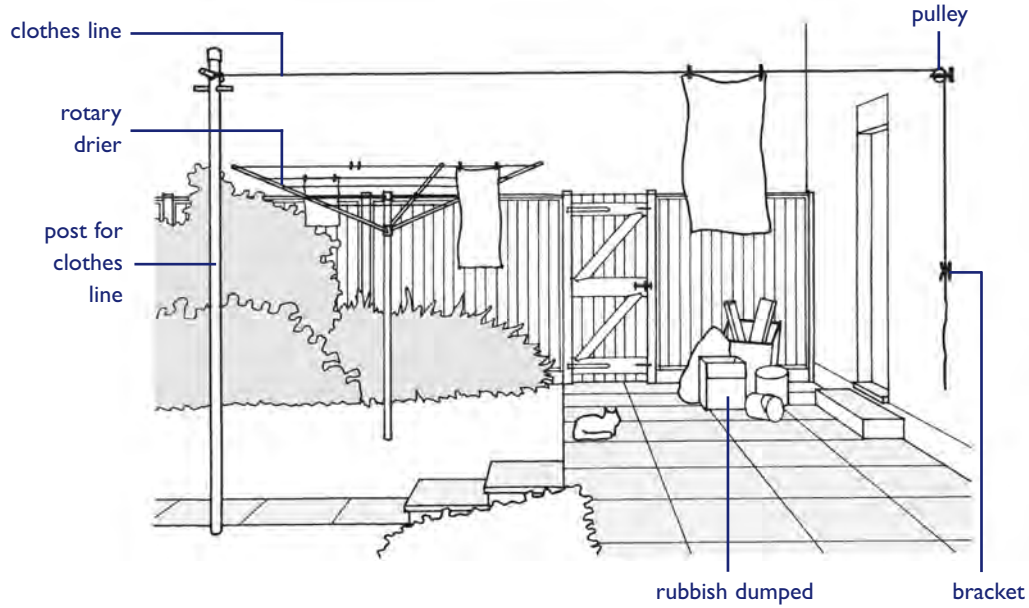

GATES

Braced gate

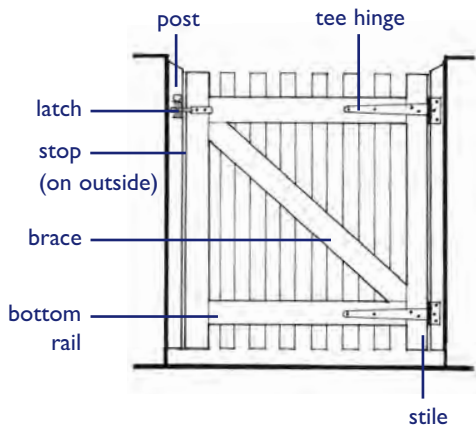

Ledged & braced gate

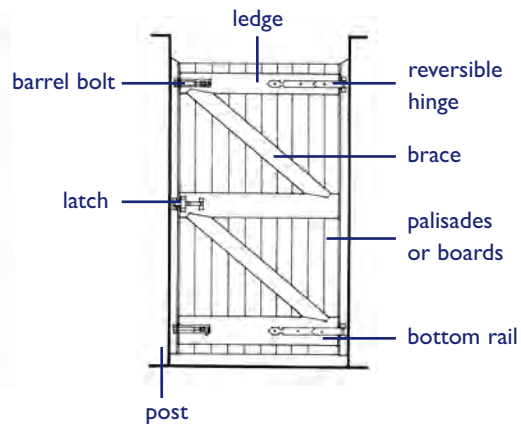

Before you contact us:

- Your rubbish is your responsibility

Tell us:

Rubbish dumped in garden

- What sort of rubbish?
- Who put it there?
- Is it hazardous?

Clothes post broken

- What is it made of? (concrete or metal etc)
- How was it broken?

Clothes line broken

- What type of clothes line is it?
- Is pulley or bracket broken

Clothes line stolen

- What type of clothes line is it?

Gate broken/rotten

- Where is gate? (front, side or rear)
- What type of gate is it? (single or double etc. See diagrams opposite)
- What is gate made of? (wood or metal)
- Does it need to be replaced or resecured?
- Can work be done without you being in?

Gate jamming

- What is gate made of? (wood or metal)
- What is causing it to jam? (hinge broken etc.)

Important notice

Minor repairs to gates and fencing are resident's responsibility eg defective latch, leaning fence.

Please contact R&CCC Team on 0800 035 1991 for further clarification.



Palisade

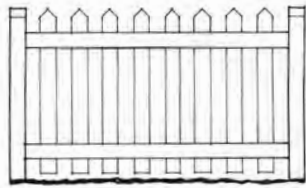

Chainlink

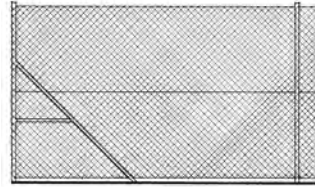

Chestnut pale

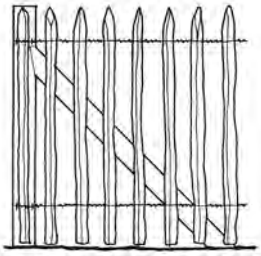

Close boarded

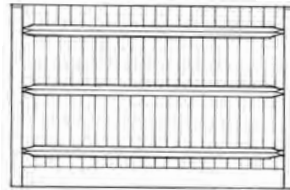

Interwoven

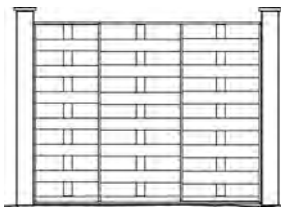

Hit & miss

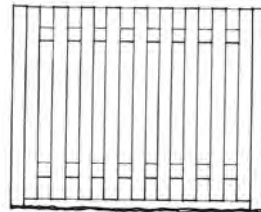

Before you contact us:

Tell us:

Gate latch/bolt broken

- What type of latch is it?
- What is gate made of?
(wood or metal etc)

Gate post rotten / broken

- What is post made from?
(wood or concrete etc)

Gate post stop defective

- What is gate post stop made from?
(wood or metal etc)

Fence dangerous/broken

- Where is fence?
(front, rear or side)
- What kind of fence is it?
(boarded, chestnut pale, timber palisade, ranch style etc. See diagrams opposite)
- What are posts and panels made of?
(wood or concrete)
- Does it need to be replaced or resecured?
- Is it your own fence or shared with your neighbour?
- How many panels are affected or what is the length of affected fencing?
- Can work be done without you being in?

Important notice

Minor repairs to gates and fencing are resident's responsibility eg defective latch, leaning fence.

Please contact R&CCC Team on 0800 035 1991 for further clarification.



Half brick wall with projecting pier

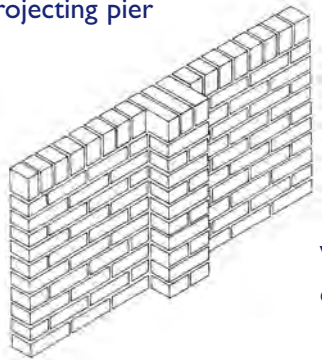

Wall with brick coping

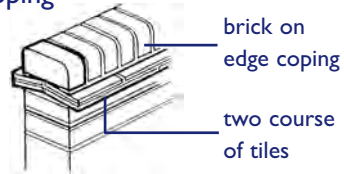

Wall with concrete or stone coping

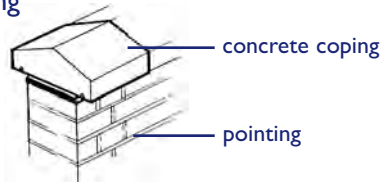

UP AND OVER GARAGE DOOR

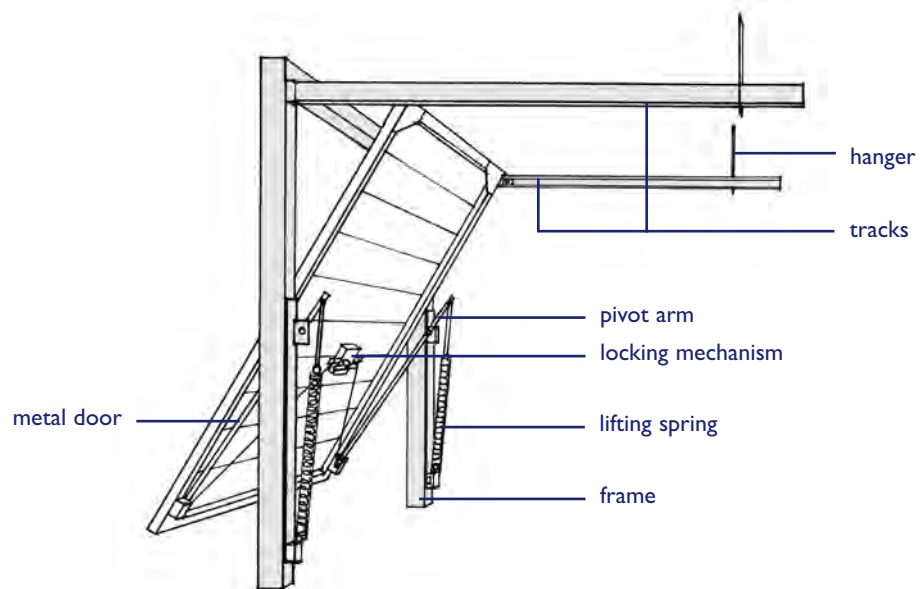

Before you contact us:

Tell us:

Wall dangerous / collapsed

- Is wall your own, or shared with a neighbour?
- What is wall made of? (brick or concrete etc)
- What part of wall is damaged? (pier, coping or pointing etc. See diagrams opposite)
- What caused the damage?
- Can work be done without you being in?

Garage door faulty

- What type of garage door is it?
- What is door made from? (wood, metal etc.)
- What is the problem? (door or frame is loose, damaged or off mechanism, lock is broken or keys are lost etc)

NOTE - Sheds

If a shed has been provided with new build property, it has been gifted. Therefore Poplar HARCA has NO responsibility for repair or replacement.

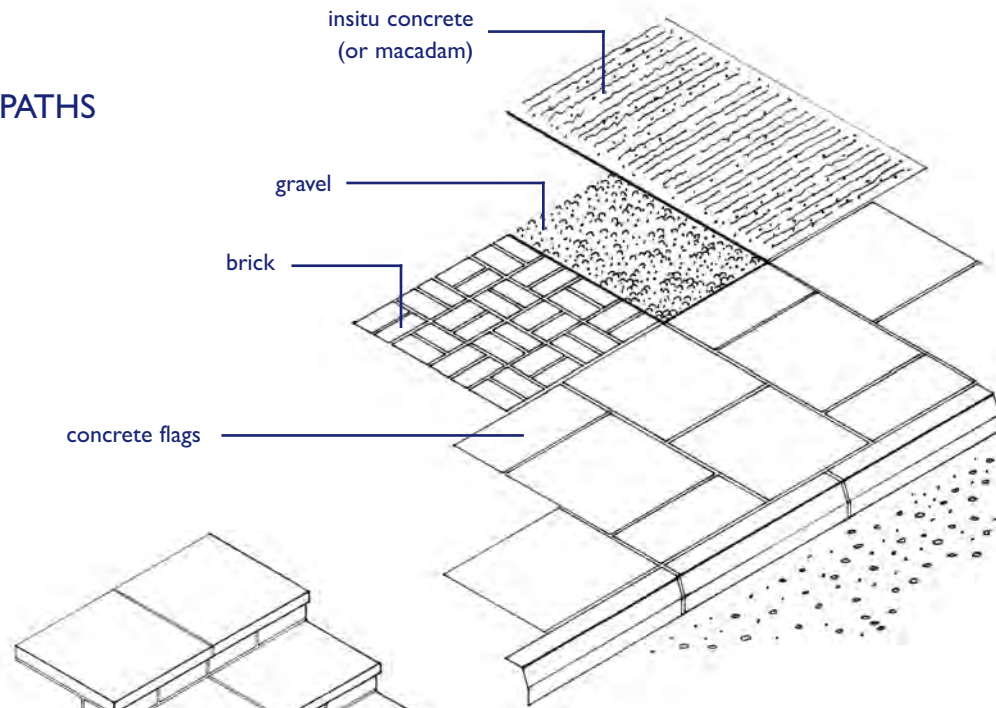

PATHS

Pre cast concrete
steps on brick

STEPS

Insitu concrete steps

Brick steps

Before you contact us:

- If dangerous, warn others.

- If dangerous, warn others.

Important notice

Paving in resident's garden is resident's responsibility.

Please contact R&CCC Team on 0800 035 1991 for further information.

Tell us:**Paving damaged**

- Where is path?
(front, rear or side)
- What type of path is it?
(flag, concrete etc. See diagrams opposite)
- What is wrong with path? (paving stones/flags are broken or loose etc)
- Does gravel path need relaying?
- Are paving stones/flags square or rectangular?
- How many are affected?
- Is it hazardous?

Steps broken

- Where are steps? (front or rear)
- What are steps made of?
(concrete, brick, etc. See diagrams opposite)
- How many steps are affected?
- Is it hazardous?
- Can work be done without you being in?



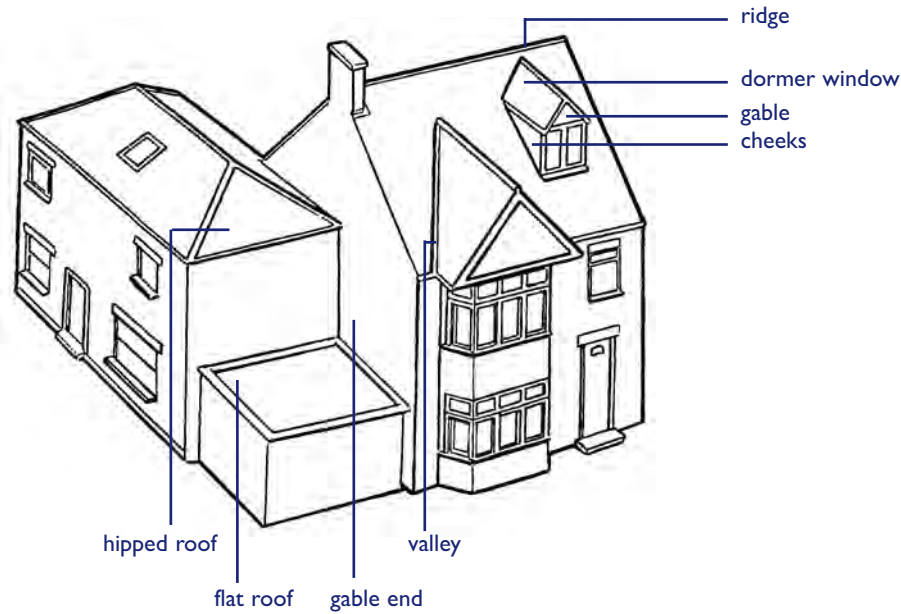

PITCHED ROOF

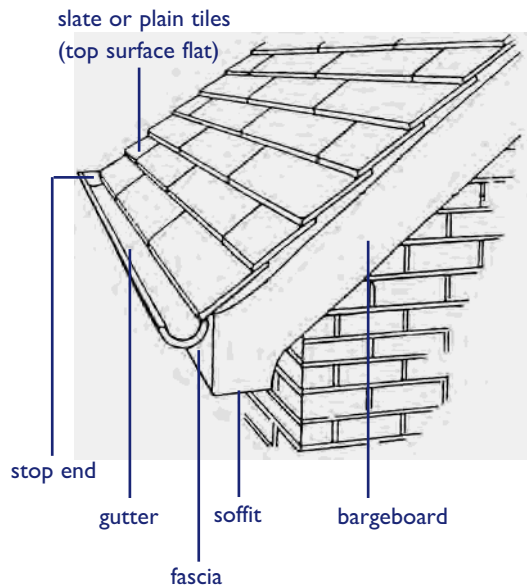

CHIMNEY STACK

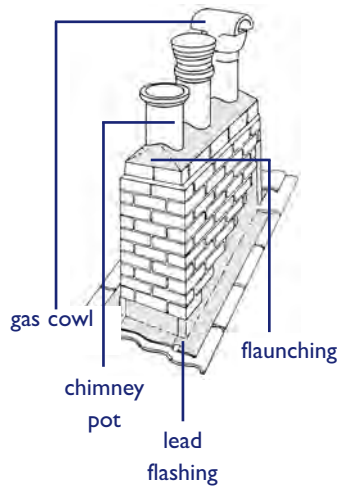

Before you contact us:

- If electrics are affected by water leakage, do not touch, and turn electricity off at consumer unit main switch.
- If there is leakage, try to stop water causing more damage. See page 71.
- If it is dangerous, warn others.

Tell us:

Tiles/slates broken

- What type of roof is it? (slate, tile etc)
- If roof is tiled, which type of tile? (plain or interlocking. See page 62)
- Are they missing, broken or loose?
- Which part of the roof is affected? (See diagrams opposite)
- How large is area affected?
- Is roof leaking?
- Does it need a tarpaulin?
- Are electrics affected?

Flat roof damaged

- What type of roof is it? (felt, asphalt or lead etc)
- Which part of roof is affected? (see diagrams opposite)
- How large is affected area?
- Is roof leaking?
- Are electrics affected?

Chimney stack damaged

- If it is dangerous, warn others.

- Which part is affected? (stack, pot or flashing etc See diagrams opposite)
- Is it damaged, loose or missing?
- Is chimney shared?
- Is it dangerous?



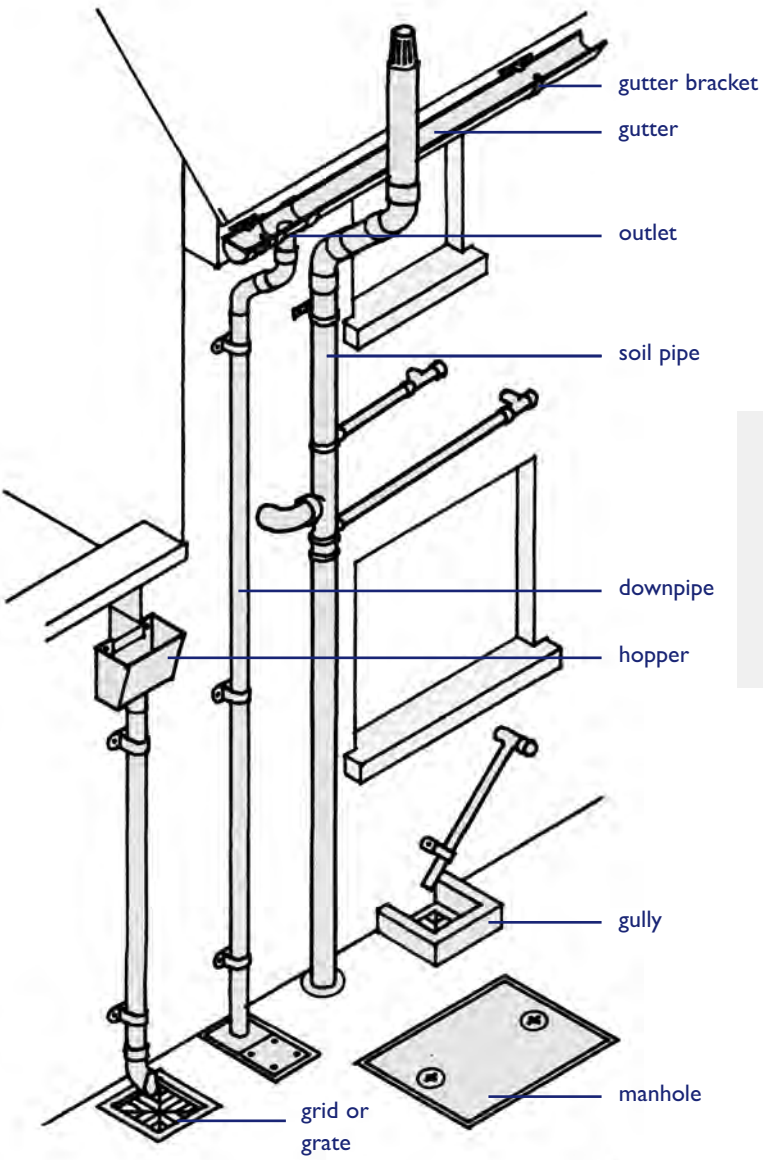

GULLIES

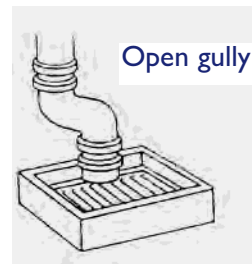
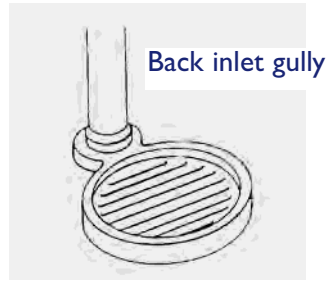

Before you contact us:

- If dangerous, put something over it to alert others to the danger.

Tell us:

Manhole cover defective

- Where is it?
- What is the problem? (loose, broken or missing)
- Is the frame damaged?
- Is it dangerous?
- Type of manhole (metal, concrete, aluminium etc)

Manhole overflowing

- Where is it located?

Gully cover defective

- Where is it?
- What is the problem? (loose, broken or missing)
- Do you think it can be refixed or does it need to be replaced?
- What is it made of?
- What size is it?

Gutter overflowing

- Where is the overflow coming from? (gutter, hopper, pipe etc. See diagram opposite)

Gully blocked

- What is blocking the gully?

Drains blocked

- What is blocking the drain?
- Is the soil pipe blocked?

- Try to clear any leaves or other rubbish yourself with a stick.

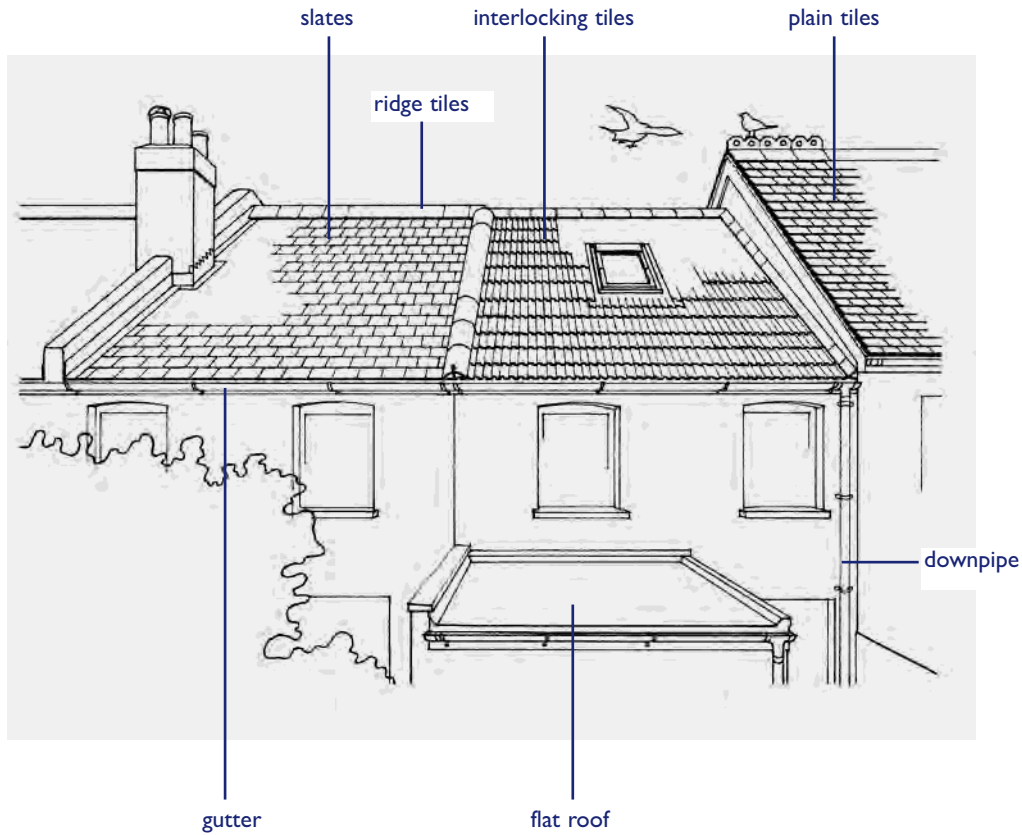

Before you contact us:

Tell us:

Guttering/downpipe defective

- What is affected?
(gutter or downpipe. See diagrams opposite and page 60)
- What is the problem?
(guttering or downpipe is blocked, cracked, loose etc)
- If it is leaking, can you tell where from?
(joint, hopper or pipe etc. See diagram page 60)
- What is it made of?
(metal, plastic etc)
- Can it be refixed or does it need to be replaced?



EXTERNAL COMMUNAL FACILITIES

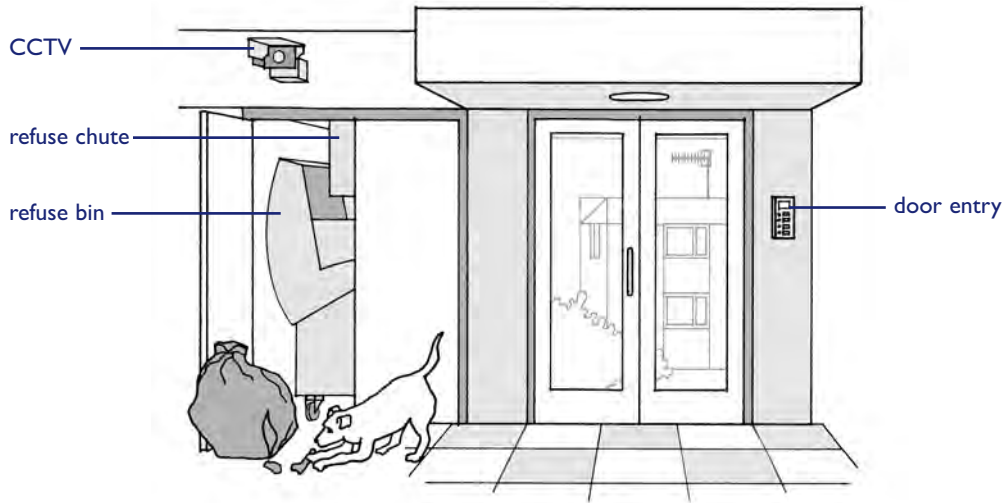

INTERNAL COMMUNAL FACILITIES

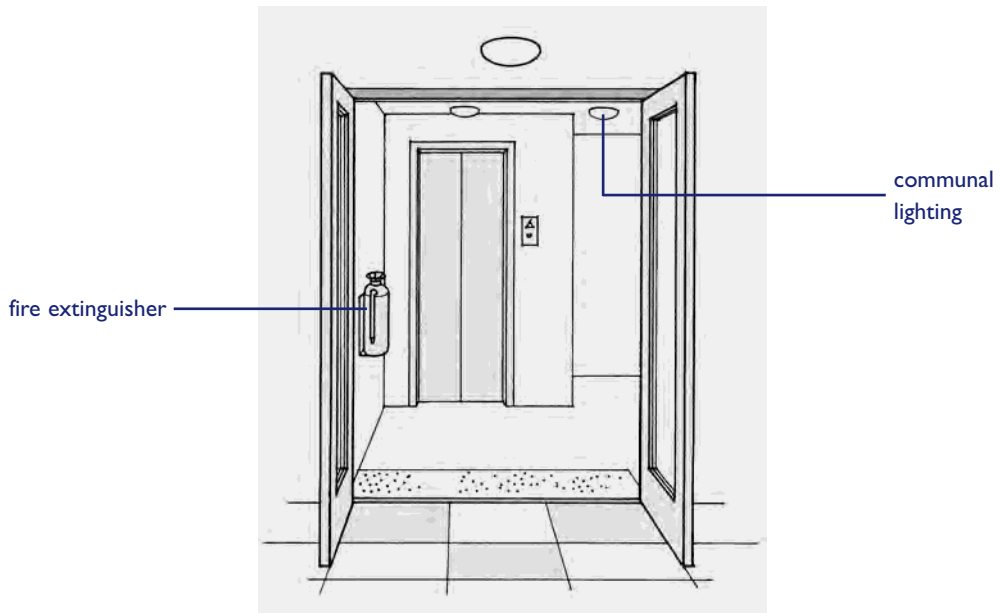

COMMUNAL

Before you contact us:

- If door is jammed, see page 27 and page 33.

- Is power cut causing the problem?
If so, contact electricity company

Tell us:

Door entry faulty

- Has whole system failed, or is only your home affected?
- Is fault at entrance or your phone?
- Is door jammed?

Emergency lighting faulty

- Which lights are affected?
- Is it failing to turn off or not coming on?

Communal lighting faulty

- Which lights are affected?
- Is it on all the time?
- Does it not come on at all?

Rubbish chute faulty

- What is wrong?
(chute is blocked, broken etc)

Services

- Is fire alarm ringing?
- Is CCTV faulty?
- Is there a problem with the communal TV aerial?



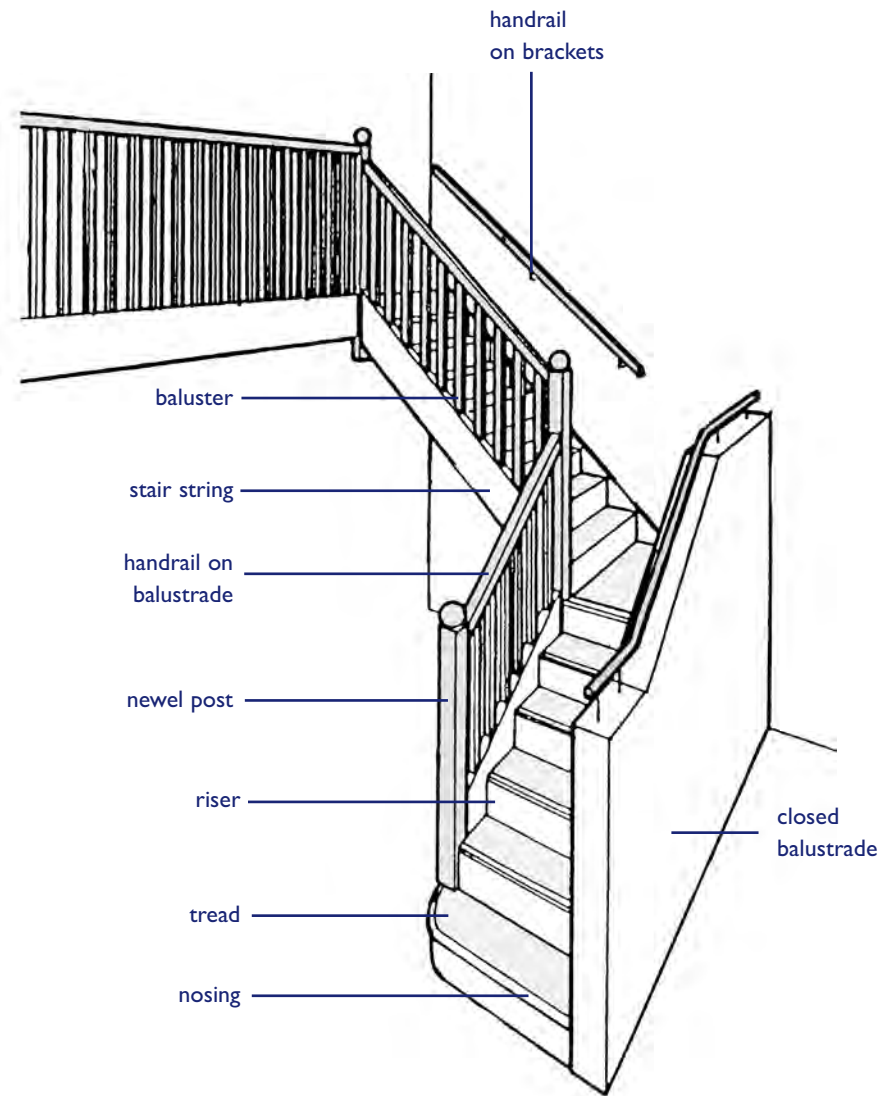

Before you contact us:

- If hazardous, warn others.
- If hazardous, warn others.

Tell us:

Loose tread

- Is it inside your home or a communal staircase?
- How many are affected?
- What are stairs made of? (wood, concrete etc)

Loose floorboard

- Is it inside your home or a communal area?
- What is the rough size of affected area?

Handrail or balustrade defective

- Is it inside your home or a communal area?
- Which part is affected? (handrail, post, individual baluster, bracket etc. See diagram opposite)
- Can it be refixed or does it need to be replaced?



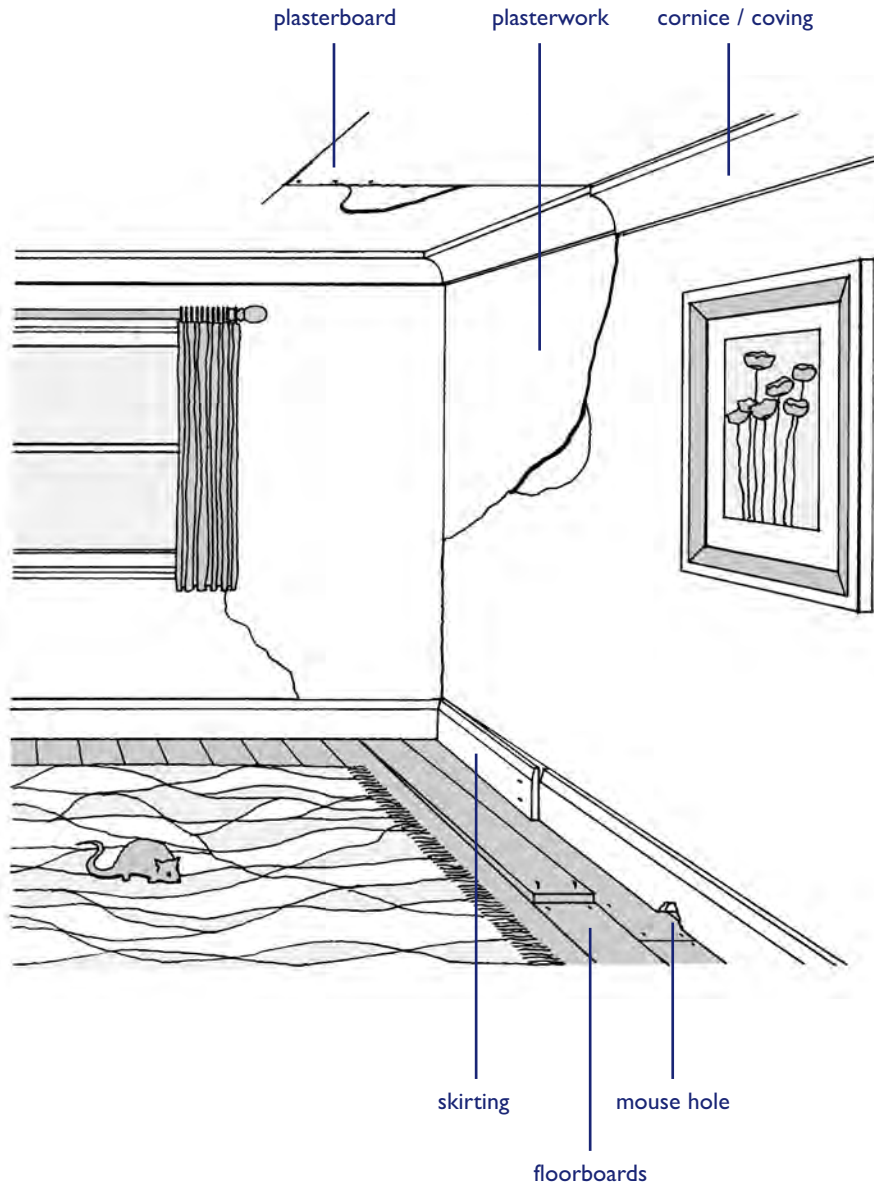

Before you contact us:

- Infestations are usually your responsibility

TIP - Pests

Insect and rodent infestation in the home needs to be dealt with quickly as infestation can spread rapidly to neighbours' homes or even the whole block.

Pests representing a health hazard (e.g. rats and cockroaches) are eradicated by the Council's Environmental Health department free of charge to residents. Call the Council and ask for Pest Control.

If you have a problem with pigeons contact the Poplar HARCA R&CCC Team who will obtain specialist advice on the best way to deal with them.

Tell us:

Floorboards

- Are floorboards loose or broken?
- If broken, is wood crumbling or rotting?

Vermin

- Have you seen mice or mouse droppings?

Plaster repairs

- Is there a crack in the plaster or is a patch damaged?
- Where is the damage? (wall, ceiling, door or window frame, coving?)
- How large is the affected area?

Skirting board

- Is the skirting board broken or loose?
- If broken, is wood crumbling or rotting?

Floor tiles

- Are tiles loose, broken or missing?
- What type of tile (ceramic, quarry, vinyl)?
- What size area is affected?



Guidance

LOOKING AFTER YOUR HOME

You are responsible for keeping the inside of your home in good condition. To help you do this it is best to carry out small tasks and checks to prevent future problems such as:

- Wipe down on a regular basis all windows affected by condensation and if any mould has formed on walls clean it off using a proprietary product available from DIY shops. See Condensation below
- Limescale can be removed from baths, sinks, shower heads, and taps with a descaler available from DIY shops
- Blockages in kitchen sink waste pipes can be prevented by flushing through using drain clearing product
- Outside gullies should be kept clear of leaves and other debris so that water drains away easily
- Make sure you know where the main stopcock is, and how to turn it off. Also, be sure to know how to turn off your electricity and gas supply in an emergency. If you do not, ask any of our staff or contractors when they next visit you
- Under no circumstances should a fire be lit in a boarded up fireplace without obtaining permission from Poplar HARCA, as there may be a serious health and safety risk.

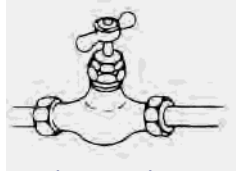

Stopcock, stop valve or stop tap

In the Autumn you should check the following list of items and notify us of any problems.

- Are all your heating controls set correctly?
- Are there any leaks or blockages from gutters and downpipes?
- Do you have any leaks from the roof?

BULK RUBBISH REMOVAL

Please help us to keep our estates looking clean, tidy and safe and do not leave rubbish or large items outside on the estate.

Tower Hamlets council will remove free of charge all bulk rubbish e.g. fridges, cookers and furniture. Phone their Streetline number (020 7364 5004) to make an appointment for them to collect such items and confirm where they will be located. They will take a maximum of 5 items at any one time. Please do not leave items outside before the day of collection as they may cause an obstruction and a fire risk.

If bags of rubbish or large items are left dumped outside on the estate we will re-charge the person responsible for the cost of clearing them away.

CONDENSATION AND MOULD GROWTH

This is a common problem during the winter months and it is essential to keep your home warm and ventilated to prevent dampness and mould growth from occurring. Condensation occurs when there is an excessive build up of moisture in the air. There is always moisture in the air, but people create additional moisture in their homes by:

- Cooking, or boiling water
- Taking baths or showers
- Using paraffin or bottled gas heaters
- Drying clothes indoors

You need to ensure that:

- You keep a window open or an extract fan on when drying clothes indoors
- Keep ALL rooms warm - cold walls cause moisture in the air to condense on the surface and results in mould growth. In cold weather keep low background heating on permanently if possible and boost this when a room is being used
- Open windows a small amount for several periods during the day or leave trickle ventilators permanently open to keep moisture levels in the air down
- Don't block vents in the home
- Do not position furniture in front of radiators
- Open windows when cooking and after bathing or showering
- Shut bathroom and kitchen doors when using these rooms
- Don't use paraffin heaters as they produce a large amount of moisture

SMOKE ALARMS

If your home does not have a mains-powered smoke alarm you are strongly advised to install a battery operated alarm.

Mains smoke alarms should be tested regularly (every 3 months is advisable) and battery alarms should be tested weekly. If the alarm is beeping intermittently the battery must be changed as soon as possible. All alarms take a standard PP3 9 volt battery obtainable at most stores.

LEAKING, BURST OR FROZEN PIPES

When pipes leak

Place a dish or bowl underneath the leak. Pull back any carpets and lay down newspapers or towels to absorb any dampness.

When pipes burst

Turn off the water at the main stopcock, and any gate valves from the water tank, and switch off any water heaters. Open all taps to drain water from the system.



Gate valve



Service valve

Can it be isolated?

Some items of equipment may have their own isolation valve (either a gate valve, or a service valve). If not, you may be able to isolate the

fault by just turning off a gate valve on a pipe coming out of the cold water tank. This will leave you with some services, even though it might only be cold water at the kitchen tap. You could then temporarily flush toilets using a bucket of cold water.

If electric fittings get wet

DO NOT TOUCH and turn off electricity at the meter

When ceilings bulge

To prevent the ceiling falling down, place a bucket under the bulge and pierce a small hole to let the water through.

When pipes freeze

Turn off the water at the main stopcock and open the cold taps. It is best to leave the pipes frozen but you may try to thaw the pipe i.e. using hot water bottles or a hair dryer. DO NOT USE A BLOW LAMP. Take care to thaw from one end of the frozen section and not from the middle. Conserve hot water until the pipes are thawed.

ASBESTOS

If you think you may have asbestos in your home, seek advice from the R&CCC Team on Freephone 0800 035 1991 before you take any action. **Do not disturb it in any way including drilling, sanding or scraping.**

Important: Asbestos is not removed unless it is, or is likely to be damaged.

If you already know asbestos is present in your property, then in the event of accidental

damage inform the R&CCC Team and do not try to repair or clean up the material yourself.

BLEEDING A RADIATOR

When to do it

If the top part of a radiator is cold, this is because air is trapped in the system. Bleeding the radiator releases this air and allows hot water to fill the whole system.

Do not bleed if

Do not bleed the radiators if you have a Combination Boiler: this type of boiler will have either a pressure gauge or a low pressure light on the front or underside of the boiler, and you will probably not have a hot water cylinder. If you have a problem with your radiators report it to the R&CCC Team on 0800 035 1991.

Bleeding a radiator

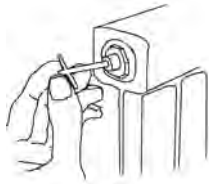

Thermostatic radiator valve

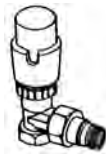

Before bleeding

If the whole radiator is cold, check that the radiator valve is open. If more than one radiator is cold, the whole heating system may need to be checked by a plumber.

Turn off the heating system before bleeding, otherwise the pump might draw more air into the system.

You will need a special radiator key, available

from most DIY and hardware shops. You will also need a rag or cloth and a bucket or bowl.

How to bleed

The bleed valve is the small square nut at the top end of the radiator. Place the key over the valve and hold the cloth around it to catch any water. Gently turn the key anti-clockwise until you hear a hiss - this is the air being released. When water starts to come through, turn the key back clockwise to shut the valve off. DO NOT unscrew the valve completely as the plug will come right out.

LOSS OF ELECTRIC LIGHT OR POWER

Warning

- Never tamper with the electricity company's fuse and seals.
- If in doubt, contact your landlord.

Turning off electricity

- If you need to turn off all electricity (eg because of water penetration), use the main ON/OFF switch on the consumer unit

Fuse or trip switch

Check your consumer unit or fuse box: it will either have fuses or trip switches (see diagrams). Modern electric circuits are fitted with a circuit breaker fuse system: if a fault develops, a switch is tripped and the circuit is broken.

When a switch is tripped

Open the cover on the consumer unit to expose the trip switches. The Consumer Unit is usually next to the electricity meter. Check which switches have tripped to the OFF

position and put them back to the ON position. For more detail, refer to any information supplied.

If tripping occurs again

It is probably being caused by a faulty appliance. You need to identify which circuit is affected and which appliance on that circuit is causing a problem.

Electricity consumer unit

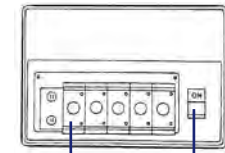

fuses or circuit breakers

main on/off switch

Fuses



Trip switch



MCB



replaces fuses in modern consumer units

Trip switch

Which appliance is faulty?

Go around the house noting which set of lights or sockets are not working. Unplug or switch off at the wall anything you think might have caused the problem. Switch the electricity off at the mains. Find the circuit breaker switch that has turned itself to 'off' and flick it back to 'on'. Switch the electricity back to 'on'.

If the switch cuts out again straightaway, or quite soon after, there could be a fault in the system - contact the R&CCC Team as soon as possible.

What causes it to trip or blow a fuse?

- An overloaded circuit
- Too many appliances being used at the same time
- A faulty or misused appliance
- Over filled kettles
- Unclean toasters
- Cooker rings worn out or cracked
- Faulty immersion heaters
- Faulty connections on leads to appliances, eg hi-fi, TV, etc
- Light bulbs blowing

Plugs

The socket outlets in your home will take square pin plugs. The plug which you require will have a fuse inside it. We do not supply plugs and you will have to obtain them yourself. To find out the correct type of fuse to fit in a plug, check the rating plate on the appliance. Do not overload plug sockets by using multiple plug adaptors.

CONTROLLING YOUR CENTRAL HEATING

How to set a digital timer

Check the clock is showing the correct time. If not, put the timer switch to 'clock' and adjust the time using the 'forward' and 'reverse' buttons. Reset the timer switch to 'auto'. Set the 'heating' and 'hot water' switches to come on once, twice, or stay on all the time, as you require. During freezing spells, keep the heating on all the time, and turn the thermostat down during the night and if you are out all day.

Heating controls



Digital programmer



Clock programmer

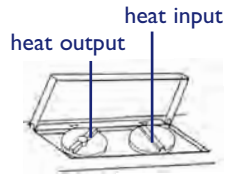

Storage heater

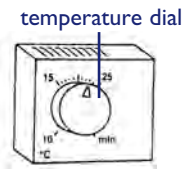

Thermostat

How to set a clock timer

Turn the clock until it is showing the correct time. Decide when you want the heating to come on and go off and set the pins or arrows for those times (see below for how to change pins and arrows). Set the timer switch to 'timer' or 'auto' as appropriate to the unit. During freezing spells, keep the heating on all the time, and turn the thermostat down during the night and if you are out all day.

How to control the temperature

To set the thermostat turn the dial so that the arrow or marker is against the temperature setting you want. A comfortable temperature is between 18°C and 22°C.

Changing pins on timeclock

Push them in against any time you want the heating on. Pull them out against any time when you want the heating off.

Changing arrows on timeclock

Slide the 'on' arrows (usually red) around the clock to the times when you want the heating to come on. Slide the 'off' arrows (usually blue) around to the times when you want the heating to go off.

CLEARING A BLOCKED WASTE PIPE

Clearing a blocked waste pipe



Bail out most of the water using a suitable container. Hold a cloth or rag firmly over the overflow opening, and place a plunger over the drain hole. Pump the plunger up and down rapidly. Plungers can be obtained from most DIY shops. After clearing the blockage, it is advisable to clean out the waste trap.

Cleaning out a waste trap

First bail out any excess water from the bath, basin, or sink using a jug or bowl. Place a bowl underneath the trap and unscrew the joints to remove the trap. Clean thoroughly and replace the trap, checking that the seals are in place and that all joints are screwed up tightly.

If more than one fitting is blocked

The problem may be in the soil stack or main drain. This will need to be cleared by one of our contractors. Blockages are usually caused

by the build-up of fat, tea leaves, hair, etc. It is advisable to clean wastes with a drain clearing product.

CLEARING A BLOCKED WC

Clearing blockages

If the pan is already full, remove most of the water into a suitable container using a jug or bowl. Push the toilet brush or plunger to the bottom of the pan and pump up and down vigorously about 10 times. This creates a vacuum and pressure which may shift the blockage. Check by flushing the toilet to see whether the blockage has gone. You may need to repeat the process several times before the toilet flushes normally. Do not use plungers with a metal disk, as these may chip or crack the toilet bowl.

Clearing a blocked WC

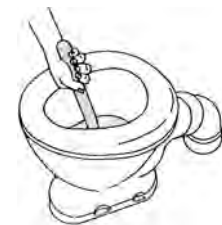

Avoiding blockages

Air fresheners that attach to the rim of the toilet pan should be fastened securely to ensure they do not fall in and cause a blockage. Blockages are usually caused by unusual objects: nappies, toys, sanitary towels, air fresheners, etc. If such a blockage occurs as a result of one or several of these objects becoming lodged, you may be charged for clearing the blockage.

Useful information

AERIALS AND SATELLITE DISHES

All residents are required to seek and obtain written permission from Poplar HARCA before installing a satellite dish. Poplar HARCA will grant permission for a satellite dish to be installed provided that the following conditions are met:

- There is no existing provision (e.g. communal satellite aerial system)
- The dish will not be installed on cladding
- No damage is caused to the building
- Written confirmation of planning approval (if required) has been provided to Poplar HARCA
- The equipment (including cabling) is installed to a recognised standard
- The dish is installed and sited to minimise environmental impact

If, in the future, Poplar HARCA undertakes the cladding of blocks, residents would be required to remove their satellite dish and re-site it so as not to damage the new cladding.

If Poplar HARCA installs communal satellite aerial systems, residents would be required to remove individual satellite dishes, without compensation.

RECHARGEABLE REPAIRS

Poplar HARCA is not responsible for any repair or replacement needed because of damage or neglect caused by you, anyone living with you or your visitors. These are listed on pages 10 and 11.

If a repair is found to be needed because of vandalism, abuse or negligence you will be charged for the cost of the repair.

If crime or vandalism is the cause of any damage a crime number must be obtained from the police in order to be exempt from being recharged.

When you vacate your property any repairs required due to damage, negligence or vandalism will be recharged to you. This includes clearance costs for any furniture, personal possessions and rubbish left within the dwelling.

However any repairs which are the residents' responsibility but are health and safety repairs are indicated under column 'Right to repair?' marked with 'Yes-Tnt'. These will be carried out by Poplar HARCA but will be recharged to the resident unless special circumstances apply.

Exceptions

There are times when we will carry out work that we would normally expect residents to do

themselves, which we will not recharge. We will do this for:

- Vulnerable residents including elderly and disabled tenants who have no immediate family/relative to undertake the repair on their behalf
- Work needed as a result of racial harassment or domestic violence

If you believe you are eligible contact the R&CCC Team for advice.

Enforcement procedures

Enforcement action, including seeking a legal injunction or reimbursement of costs, may be taken where breaches of tenancy conditions have occurred. These include:

- Making unauthorised alterations to premises
- Installation of satellite dishes and security grilles and gates without permission
- Refusal to allow access to carry out gas servicing
- Repairs required due to damage, misuse or neglect, including to vacated property
- Clearance of abandoned possessions from vacated property

CRIME AND VANDALISM

If you have suffered damage to your home from a break-in, attempted break-in or vandalism we will repair the damage at no charge. You must first, however, report this to the police and obtain a crime number. If you fail to provide a crime number you will be recharged.

BOGUS CALLERS

All Poplar HARCA employees and contractors must carry a photo identification card when calling at your home.

For your own safety please ensure you ask to see this before allowing any caller into your home. If you are still unsure of the identity of the caller please ring the R&CCC Team (0800 035 1991) for advice.

COMPLAINTS

Poplar HARCA is committed to providing its residents with the best possible service, but we know we don't always get it right. If we have made a mistake or if our service is not up to scratch, we will apologise and try to remedy the situation as quickly as possible.

If we have not resolved the problem to your satisfaction you do have the formal right to complain.

If you have a complaint about any part of the repairs service contact the R&CCC Team who will arrange to have this investigated for you.

Poplar HARCA has a 3 stage complaints procedure with prescribed timescales for each stage which must be followed by its officers. A copy of this procedure is obtainable from the R&CCC Team.

Should you still be dissatisfied, you can take your complaint to the Independent Housing Ombudsman. This is an independent and impartial organisation which has the authority

to investigate whether or not a social housing provider has acted unfairly or if a complaint has been caused by maladministration.

ADAPTIONS FOR ELDERLY AND DISABLED RESIDENTS

Many tenants struggle with normal daily living activities such as climbing steps or stairs, getting in and out of a bath and turning taps. Our service works with Occupational Therapists to assess your needs and to provide adaptations to your home to make life easier.

Grants are available from London Borough of Tower Hamlets for major adaptations such as stair-lifts, ramps and bathroom alterations. Poplar HARCA can make an application on your behalf and arrange for these works to be carried out if you wish us to do so.

Minor adaptations such as grab rails can be installed by Poplar HARCA. An Occupational Therapist's assessment and recommendation is required before any adaptations can be fitted. Contact your local Social Services department for an assessment.

PERFORMANCE AND QUALITY CONTROL

We are committed to providing a high quality repairs service and regularly set, monitor and review repairs performance targets. The performance of the Repairs Service is reported monthly to the Corporate Management Team and quarterly to Poplar HARCA board meetings.

Please also help us to improve our service by completing feedback forms which are posted to a percentage of households on a random basis after a repair has been carried out. Satisfaction surveys are also carried out from time to time and your co-operation in completing these is appreciated.

DIVERSITY AND SUPPORT & INCLUSION TEAM

Poplar HARCA is committed to providing an equal accessed, high quality, ease of reporting Repairs Service to all our residents.

Our Support & Inclusion Team work with our vulnerable and elderly residents to ensure requested support is provided when contractors attend to carry out repairs.

If you are elderly or class yourself as vulnerable and require support, please call 020 7510 0553 for advice and assistance.



Poor Mr Smith woke up one morning to discover he had leaks coming through his sitting room ceiling.



He immediately called Poplar HARCA's R&CCC Team. They were very understanding and immediately logged the repair.

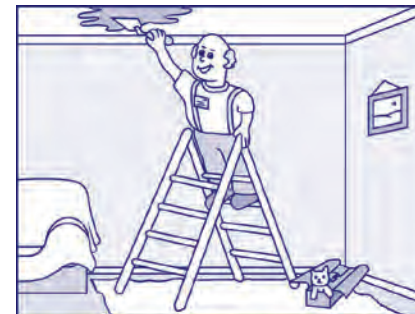

Within 24 hours the leak was fixed and Poplar HARCA's Repairs Operative was in his home repairing his ceiling

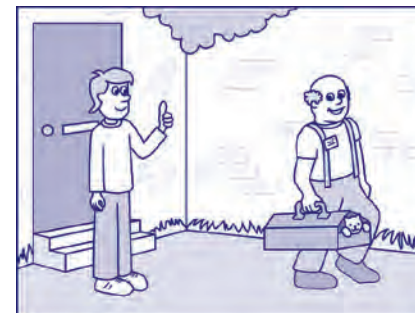

Mr Smith was very happy and thanked Poplar HARCA for such a quick and professional service.

Index

A

Adaptations for elderly/disabled 78
Aerials 11, 76
Alterations and improvements 8
Appointments 9
Asbestos 72

B

Basin repairs 5-7, 10, 13-15, 75
Bath repairs 5, 7, 10, 12-13, 15,
18-19, 70-71, 75
Blocked sinks/toilets, prevention 15,
17, 75
Blocked sinks/toilets, unblocking 15,
17, 41, 70, 75
Bogus callers 77
Boiler (central heating) faulty 43
Bulk rubbish removal 70
Burst pipes 1, 4, 7, 10, 23, 71

C

Ceiling repairs 11, 69, 72
Chimney damaged 59
Communal area repairs 11, 35, 43, 64-
65, 67, 76
Compensation for
home improvements 8
Compensation for
missed appointments 9
Compensation for
Right to Repair scheme 7
Complaints 9, 77
Condensation 70-71
Corporate Management Team 78
Crime and vandalism 76-77
Cupboard 8, 11, 39

D

Damage by resident 6-7, 10-11, 76-77
Dampness and water penetration 10,
70-71, 72
Disability 78
Diversity, support and inclusion 78
Door entry repairs 5, 9, 11, 65
Door (internal) repairs 10, 27-33, 65
Door (external) repairs 4-5, 10, 26-
31, 64-65
Downpipe / guttering faulty 60, 62-63,
70
Drains blocked 4, 10, 60-61, 63
Drinking water 1, 11

E

Elderly tenant 4, 6, 77, 78
Electrical repairs 1, 4-5, 8-10, 13, 19,
23, 25, 43-47, 49, 59, 72-73
Electricity safety 4, 8, 13, 23, 45, 47,
59, 70, 72-73
EMERGENCIES 1, 7
Enforcement 77
Exceptions to resident
responsibilities 6, 76-77
External boundary repairs 11, 51-55
External wall repairs 11, 55
Extract fan faulty 5, 10, 38, 46-47, 71

F

Feedback on repairs 4, 9
Fence dangerous / broken 11, 52-53
Fireplace 70
Flooding 1
Floor and wall tiling repairs 12, 14-15,
21, 38-39, 69
Flooring repairs 4
Fumes in room 45

G

Garage repairs 54-55
Gate repairs 6, 11, 27, 35, 50-51, 53,
77
Gas emergencies 1, 4, 7, 70
Gas leak 1, 7, 45
Gas servicing 6
Graffiti removal 1, 11
Guidance 70
Gully 60-61
Guttering / downpipe repairs 11, 58,
60-63, 70

H

Heating and hot water repairs 1, 4-7,
10, 19, 21-22, 25, 42-43, 45, 70-72, 74,
75
Holidays, leaving your home empty 7

I

Identification, of callers 9, 77
Insurance 5
Internal wall repairs 6, 11

K

Keys lost 29, 31, 55
Kitchen repairs 5, 11, 23, 38-39, 70, 72

L

Leak repairs 1, 4-5, 7, 10-11, 13, 17,
23, 41, 45, 59, 63, 70-71
Leaving your home empty 7
Lift repairs 1, 11, 78
Lighting repairs 4, 6, 8, 10-11, 46-48,
64-65, 73-74
Locked out 29, 31

M

Manhole repairs 60-61
Minor repairs 6, 10-11
Mould growth 6, 70-71

O

Occupational Therapists 78
Out of hours emergencies 1

P

Path damaged 56-57
Performance 9, 77, 78
Pests 69
Pipe repairs 1, 4-7, 10, 12-13, 15-17,
22-23, 41, 45, 60-63, 70-72, 75
Plug sockets 8, 10, 45, 47-49, 73-74
Power: none at all 4, 19, 25, 45, 47, 49,
65, 73
Prioritising repairs 4-5, 10-11

R

Radiator repairs 10, 43-45, 72
Rechargeable repairs 77
Redecorations 6
Repairs reporting 1, 4-6, 9
Repairs service 1
Resident surveys 4, 76
Responsibilities: HARCA 10-11
Responsibilities: resident 10-11
Right to Repair 7, 10-11, 77
Roof repairs 4-5, 10-11, 59, 63, 70
Rubbish chute repairs 65

S

Sanitary fitting repairs 10
Satellite dishes 77
Satisfaction 9, 77
Sealing strip repairs 12, 14-15, 19-21,
38, 41, 75
Security grilles and gates 27, 35, 77

Showers repairs 18-21, 71
Sink repairs 5-7, 10, 13, 15, 17, 23, 38-
41, 71, 75
Slates damaged 11, 58-59, 62
Smoke alarms 48-49, 71
Soil stack blocked 4, 16, 19, 61, 75
Splashback / tiles damaged 12, 14-15,
21, 38-39
Stairs 66-67

T

Tank (storage) overflowing 5, 10, 17,
22-23, 71
Tap repairs 4, 7, 10, 13-15, 17, 23, 40-
41, 70-72
Threshold damaged 26-27
Tiles (wall) damaged 12, 14-15, 21, 38-
39
Toilet/WC repairs 5-6, 10, 15-17, 19,
72, 75
TV aerial repairs 11, 65, 76-77

V

Vulnerable tenant 4, 6, 77, 78

W

Walls 11, 29, 38-39, 44, 46-47, 54-55,
68-69, 71, 73
Washing machine repairs 40-41
Waste pipe repairs 10, 12-15, 17, 20,
40-41, 70, 75
Water related items 4-7, 10-11, 13,
17, 19, 21-25, 43, 59, 70-75
WC 5-6, 10, 15-17, 19, 72, 75
Weatherboard damaged 26, 29
Window repairs 1, 4-7, 10, 27, 35-37,
45, 58
Woodwork repairs 11

See cover a/w